

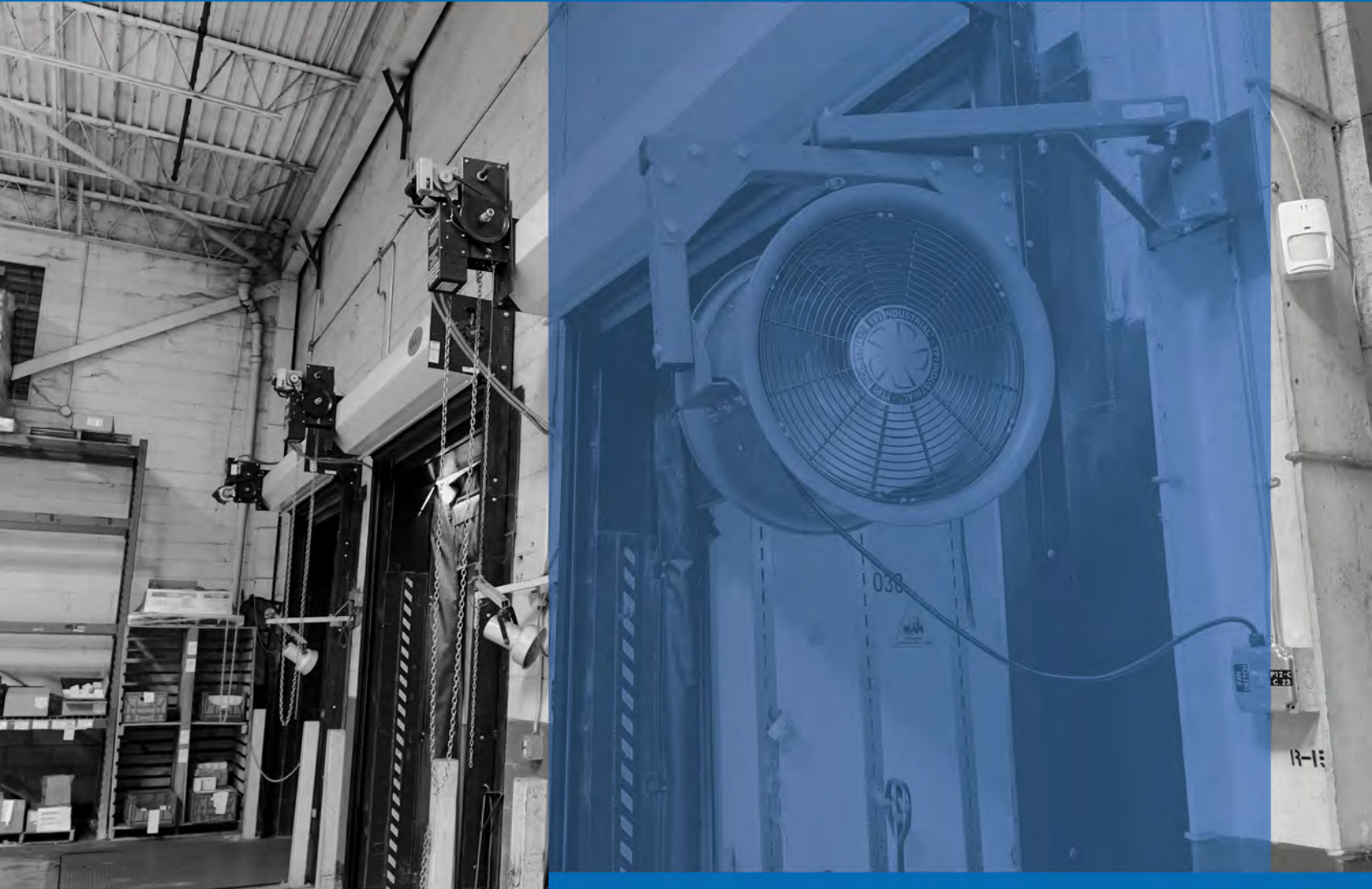

TPI CORPORATION

America's Comfort Conditioning Company

2022 ELECTRICAL PRODUCTS CATALOG



VENTILATION, FANS, & INDUSTRIAL LIGHTING

INDUSTRIAL | COMMERCIAL | RESIDENTIAL

Tel: 1-800-682-3398 | 1-423-477-4131 | Fax: 1-423-477-0064 | www.tpicorp.com

www.linkedin.com/company/tpi-corporation/ www.facebook.com/tpicorporation

LIGHTS

FANS

Table Of Contents & Limited Warranty

| CATEGORY | PAGE |
|---|-------|
| INDUSTRIAL CIRCULATORS | |
| 24" & 30" Assembled Maximum Duty | 2 |
| 20" to 36" Assembled Circulator Heads & Mounts | 3 |
| 20" 24" & 30" Unassembled Circulators | 4 |
| 20" 24" & 30" Specialty Circulator Heads | 5 |
| Components - Motor Comparisons | 6 |
| Air Circulators - Motor Comparisons | 7 |
| COMMERCIAL CIRCULATORS | |
| 20", 24" & 30" Commercial Non-Osc. Circulators | 8 |
| 20", 24" & 30" Commercial Oscillating Circulators | 8 |
| COMMERCIAL BLOWERS | |
| 36" 42" & 48" Belt Drive Portable | 9 |
| 24" 30" & 36" Direct Drive Portable | 9 |
| INDUSTRIAL BLOWERS | |
| 30" 36" & 42" Direct Drive Portable | 10 |
| 48" Direct Drive Portable | 10 |
| 36" 42" & 48" Belt Drive Portable | 11 |
| 30" 36" & 42" Direct Drive Suspension | 12 |
| 36" 42" & 48" Belt Drive Suspension | 12 |
| 24" & 30" Mini | 13 |
| Heavy Duty Square Belt Drive Portable | 13 |
| High Velocity | 14-15 |
| Heavy Duty Direct Drive | 16 |
| Heavy Duty Permanent Mount Direct Drive | 17 |
| WORKSTATION FANS | |
| Industrial Floor | 18 |
| Corrosion Resistant Industrial Floor | 18 |
| Industrial Mounted | 19 |
| Outdoor Rated Yoke Mount | 19 |
| Commercial Floor | 20 |
| Oscillating Office | 20 |
| Wall Mounted With Pivoting Arm | 21 |
| Low Velocity "Special Application" | 21 |
| MISTING FANS | |
| 18" Portable Self Contained | 22 |

| CATEGORY | PAGE |
|---|--------------|
| CEILING FANS | |
| Industrial Ceiling Fans | 23 |
| EXHAUST FANS & GUARDS | |
| Shutter Mounted Direct Drive | 24 |
| Guard Mounted Direct Drive | 25 |
| Venturi Mounted Direct Drive | 26 |
| Commercial Belt Drive - (Fans & Shutters) | 27 |
| Industrial Direct Drive | 28 |
| Industrial Belt Drive | 29 |
| Heavy Duty Direct Drive | 30 |
| Heavy Duty Belt Drive | 31 |
| Cabinet Exhaust Fans With Shutters | 32 |
| Accessories / Heavy Duty Shutters | 33 |
| Cabinet Accessories / Guards | 34 |
| Cabinet Exhaust Fan Package Options | 35 |
| Weather Hood | 35 |
| ROOF VENTILATORS | |
| Insulated Roof Curbs | 36 |
| Belt Drive Hooded Roof Ventilator | 37 |
| Direct Drive Roof Ventilator | 38 |
| Belt Drive Roof Ventilator | 39 |
| TUBEAXIAL DUCT FAN | |
| Direct Drive & Guards | 40 |
| Belt Drive | 41 |
| ATTIC FANS | |
| Roof Domes, Gable Fans, Attic Fans | 42 |
| INDUSTRIAL LIGHT PRODUCTS | |
| Loading Dock Lights | 43 |
| Modular Loading Dock Lights | 44 |
| Machine Tool Lights | 45 |
| Commercial Utility Lights | 45 |
| PRODUCT INDEX | 46-50 |

TPI Corporation provides a limited warranty of materials and workmanship for a period of (i) ten (10) years for elements in 2900 Series baseboard heaters, (ii) two (2) years for Thermostats and Controls, (iii) five (5) years on HD and HDH series fans, (iv) three (3) years on UHP and IHP series fans, (v) and twelve (12) months for all other products, with the warranty period commencing on the original date of purchase. The TPI warranty is limited to materials manufactured and work performed by TPI Corporation, and does not include damage or failure caused by acts of God, abuse, misuse, connected to or placed on other than rated voltage, abnormal usage, faulty installation, failure to follow suggested maintenance procedures enclosed with the product, improper maintenance or any repairs other than those provided by an authorized TPI Corporation service center. For the name of your nearest authorized TPI Corporation service center, please write to TPI Corporation, P.O. Box 4973, Johnson City, Tennessee, 37602 or call 1-800-682-3398.

During the warranty period, TPI Corporation will, at its sole option, repair or replace any defective parts or products returned, freight prepaid, to the TPI Corporation factory or such other location as TPI Corporation may designate. No parts or products will be accepted for repair or replacement without prior authorization from TPI Corporation and a return merchandise authority (RMA) number issued by TPI Corporation. Returned products must be packaged carefully and TPI Corporation shall not be responsible for damage in transit. When returning parts, the owner must provide the model number of the product and nature of difficulty being experienced.

This warranty does not obligate TPI Corporation to bear the cost of labor in replacing any assembly, unit or component part thereof, nor does TPI Corporation assume any liability for secondary charges, expenses for installing or removal, freight or damages. There will be charges rendered for product repairs made after the warranty period has expired. Proof of purchase, including date, must accompany request for in-warranty service. This warranty gives you specific legal rights and you may have other rights, which may vary, from state to state.

Except for the limited warranty provided in the foregoing paragraph, all parts and products sold by TPI Corporation are sold 'as is', 'where is', and without any other warranty of any kind or nature, whether express, implied, or statutory and including, without limitation, any implied warranty of specific performance or merchantability.

Under no circumstances, even with respect to claims covered by the foregoing warranty, will TPI Corporation be responsible for any incidental, consequential, special, or punitive damages of any kind or nature arising from or related to the parts or products sold by TPI Corporation.

In any event, TPI Corporation's maximum liability shall not in any case exceed the purchase price for the part or product claimed to be defective.

You hereby expressly agree to waive any and all rights to a trial by jury with respect to any product manufactured or supplied by TPI Corporation.

| Ventilation Products Warranty Coverage | |
|--|---------|
| Series HD or HDH fans | 5 Years |
| Series UHP or IHP fans | 3 Years |
| All other ventilation products | 1 Year |

RETURN POLICY:

Requests for returns of non-defective standard stock units may incur testing and repackaging charges if units are not in like new condition. Requests for returns of build to order items are subject to cancellation charges prior to shipment and up to a 100% restocking charge after shipment. This also applies to any standard model with factory installed control options or other custom features. Changes made to custom products during production may incur labor charges. Please consult factory for details on any return or change order

TPI COMMERCIAL CIRCULATORS STATEMENT:

TPI Commercial circulators have been developed to equal the imported circulators that are sold by big-box retail stores and some catalogers. Because these circulators do not have totally enclosed motors, they should be used in clean, dry commercial applications - such as schools, shops, offices, and warehouses. Note: Prices subject to change without notice.

TPI Industrial Assembled Maximum Duty Circulators

Features

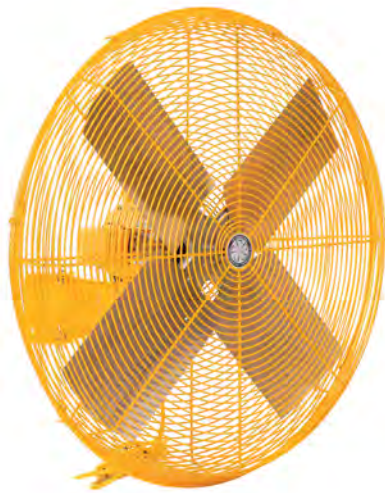

HDH Series

- Steel construction with safety yellow textured epoxy powder coated finish
- Direct drive, Totally Enclosed Air-Over (TEAO) motor generating up to 8,000-CFM's
- Aluminum 4-paddle blade system with steel hub and cast aluminum spider connections
- HDH-Series contains a pull-chain switch and 12' long SJT-Type cord with grounded plug
- HDH-JR Series contains a 12' long SJT-Type cord with grounded plug and 18" long drop-down cord assembled with an electrical (off, on low/high) switch enclosure
- Fully-Assembled Non-Oscillating fan heads in 24" or 30" diameter sizes
- 5-year motor warranty
- Made in the U.S.A. with domestic and foreign components

Motor Specifications

- 2-Speed
- 1-Phase, 120V
- Permanent split capacitor
- Frame size: 48
- 1/2 HP
- Ball bearing
- Totally enclosed, permanently lubricated
- 1/2" Shaft

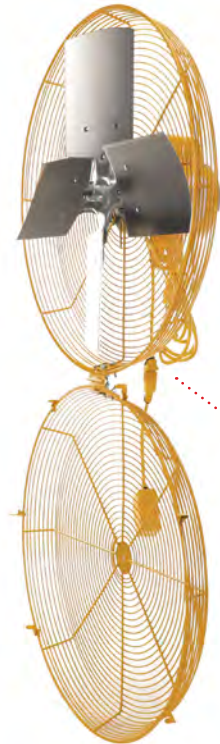

Hinged Guard



HDH-JR Series

Drop-Down Switch



Wall Mount see pg. 6

| DIMENSIONS | |
|------------|------------------------------|
| 24" | 27" Diameter x 14.5" Depth |
| 30" | 33.5" Diameter x 14.5" Depth |



Pedestal Mount, see pg. 6



WARNING: This product can expose you to chemicals including nickel which is known to the State of California to cause cancer, and chromium, which is known to the State of California to cause birth defects and/or reproductive harm. For more information go to www.P65Warnings.ca.gov.

Standard Models

| ASSEMBLED FAN HEAD | | BLADE SIZE | SWITCH TYPE | HP | CFM* / RPM | | VELOCITY PROFILE | | AMPS | WT. (LBS) | LIST |
|--------------------|------------------|------------|-------------|-----|-------------|------------|------------------|--|------|-----------|------------|
| MFG CATALOG NUMBER | MFG MODEL NUMBER | | | | HIGH | LOW | CFM / Area Sq Ft | | | | |
| 08744402 | HDH 24-JR | 24" | Drop Down | 1/2 | 5600 / 1100 | 4900 / 800 | 7500 / 260 | | 3.5 | 44 | 860 |
| 08744602 | HDH 30-JR | 30" | | | 6800 / 1100 | 6000 / 800 | 8000 / 270 | | 4 | 48 | 884 |
| 07960702 | HDH 24 | 24" | Pull Chain | | 5600 / 1100 | 4900 / 800 | 7500 / 260 | | 3.5 | 44 | 788 |
| 07960802 | HDH 30 | 30" | | | 6800 / 1100 | 6000 / 800 | 8000 / 270 | | 4 | 48 | 806 |

*Measured 2 feet from face of fan

TPI offers six factory assembled and tested fan mounts that can be used with any of the non-oscillating TPI Industrial heads.

TPI Industrial Assembled Circulator Heads and Mounts

Features

- Steel construction with silver/gray powder coated; steel motor housing painted black
- Direct drive, Totally Enclosed Air-Over (TEAO) motor generating up to 12,000-CFM's
- Aluminum 3-paddle blade system with steel hub and cast aluminum spider connections
- All models contain a pull-chain switch and 12' long SJT-Type cord with grounded plug
- All models, except HDH-36, contain self-locking retaining clips to secure front/rear grills and meet OSHA safety requirements
- HDH-36 model operates at single speed, contains interlocking front/rear grills and includes a heavy-duty wall mounting bracket inside the carton
- HDH-GJR Series contains a 12' long SJT-Type cord with grounded plug and 18" long drop down cord assembled with an electrical (off, on low/high) switch enclosure
- Fully-Assembled ready for plug-&-play operation offered in Non-Oscillating (Stationary) and Oscillating fan heads in 20", 24" or 30" diameter sizes; mounts sold separately
- Oscillating models rotates in a 90° arc or can be locked in a fixed position
- Metal gears in the oscillating model allow the fan to operate at a maximum 30° downward tilt
- Motor warranty ranges from 1, 3 and 5-years
- Made in the U.S.A. with domestic and foreign components



ACM-IHP-HDH Series



HDH-G-JR Series
Drop-Down Plug and Hinged Guard



ACH-O Series
Oscillating Motor

Motor Specifications

- 2-Speed
- 1 Phase, 120V
- Ball bearing
- Frame size: 48
- Totally enclosed
- Permanent split capacitor
- Permanently lubricated
- 1/2" Shaft

| DIMENSIONS | |
|------------|------------------------------|
| 20" | 22" Diameter x 14.5" Depth |
| 24" | 27" Diameter x 14.5" Depth |
| 30" | 33.5" Diameter x 14.5" Depth |



WARNING: This product can expose you to chemicals including nickel which is known to the State of California to cause cancer, and chromium, which is known to the State of California to cause birth defects and/or reproductive harm. For more information go to www.P65Warnings.ca.gov.

Standard Models

| H.P. | BLADE SIZE | MFG MODEL NUMBER | MFG CATALOG NUMBER | FAN HEAD TYPE | CFM* | VELOCITY PROFILE | RPM | AMPS | WT. (LBS) | LIST |
|----------------------------|------------|------------------|--------------------|---------------|-------------|------------------|------------|------|-----------|------------|
| | | | | | | CFM / Area Sq Ft | | | | |
| 1 Year Warranty | | | | | | | | | | |
| Industrial 1/4 | 20" | ACH 20 | 08684702 | STATIONARY | 3000 / 2600 | 5000 / 200 | 1100 / 900 | 2.4 | 39 | 403 |
| | 24" | ACH 24 | 07961602 | | 3800 / 3400 | 6000 / 240 | 1100 / 800 | 2.5 | 40 | 453 |
| | 30" | ACH 30 | 07961702 | | 4300 / 3800 | 7200 / 250 | 1100 / 800 | 2.7 | 44 | 467 |
| 3 Year Warranty | | | | | | | | | | |
| High Performance 1/3 | 24" | IHP 24-H | 07989802 | STATIONARY | 4300 / 3900 | 6000 / 240 | 1100 / 800 | 2.8 | 40 | 576 |
| | 30" | IHP 30-H | 07989902 | | 5400 / 4700 | 7200 / 250 | 1100 / 800 | 3 | 44 | 603 |
| 5 Year Warranty | | | | | | | | | | |
| Heavy Duty 1/2 | 24" | HDH 24-G | 08539202 | STATIONARY | 5600 / 4900 | 7500 / 260 | 1100 / 800 | 3.5 | 44 | 755 |
| | 30" | HDH 30-G | 08528602 | | 6800 / 6000 | 8000 / 270 | 1100 / 800 | 4 | 48 | 780 |
| | 24" | HDH 24-GJR | 08745002 | | 5600 / 4900 | 7500 / 260 | 1100 / 800 | 3.5 | 44 | 860 |
| | 30" | HDH 30-GJR | 08745102 | | 6800 / 6000 | 8000 / 270 | 1100 / 800 | 4 | 48 | 884 |
| | 36" | HDH 36 | 08197802 | | 6970 | 12000 / 325 | 1100 | 5.2 | 90 | 851 |
| 1 Year Warranty | | | | | | | | | | |
| Industrial Oscillating 1/4 | 20" | ACH 20-O | 08684802 | OSCILLATING | 3000 / 2600 | 5000 / 200 | 1100 / 900 | 2.4 | 43 | 610 |
| | 24" | ACH 24-O | 07963602 | | 3800 / 3400 | 6000 / 240 | 1100 / 800 | 2.5 | 44 | 695 |
| | 30" | ACH 30-O | 07963702 | | 4300 / 3800 | 7200 / 250 | 1100 / 800 | 2.7 | 48 | 720 |

*Measured 2 feet from face of fan

HDH-36 Note: Wall mount only, mount included, unit imported to TPI specifications.

TPI offers six factory assembled and tested fan mounts that can be used with any of the non-oscillating TPI Industrial heads.

TPI Industrial Unassembled Circulators

Features

- Unassembled packaged kits, include: motor, blade, guards & mount (pedestal or wall)
- Steel construction with silver/gray powder coated; steel motor housing painted black
- Direct drive, Totally Enclosed Air-Over (TEAO) motor generating up to 7,200-CFM's
- Aluminum 3-paddle blade system with steel hub and cast aluminum spider connections
- All models contain a pull-chain switch and 12' long SJT-Type cord with grounded plug
- All models contain self-locking retaining clips to secure front/rear grills and meet OSHA safety requirements
- Offered in Non-Oscillating (Stationary) and Oscillating fan heads in 20", 24" or 30" diameter sizes
- Oscillating models rotates in a 90° arc or can be locked in a fixed position
- Metal gears in the oscillating model allow the fan to operate at a maximum 30° downward tilt
- Pedestal pole adjusts the center of fan from 48" to 67" tall; bolts to 27" diameter steel dome with 5-bolts
- Motor warranty from 1 or 3-years
- Made in the U.S.A. with domestic and foreign components



UHP-P Series



ACU-WO Series

Oscillating Fan Head with Wall Mount



| DIMENSIONS | |
|------------|------------------------------|
| 20" | 22" Diameter x 14.5" Depth |
| 24" | 27" Diameter x 14.5" Depth |
| 30" | 33.5" Diameter x 14.5" Depth |

WARNING: This product can expose you to chemicals including nickel which is known to the State of California to cause cancer, and chromium, which is known to the State of California to cause birth defects and/or reproductive harm. For more information go to www.P65Warnings.ca.gov.

Motor Specifications

- 2-speed
- 1-Phase, 120V
- Ball bearing
- Frame size: 48
- Totally enclosed
- Permanent split capacitor
- Permanently lubricated
- ½" Shaft

Standard Models

| FAN TYPE | | MAXIMUM DUTY | MAX AMPS | HIGH PERFORMANCE | MAX AMPS | INDUSTRIAL | MAX AMPS | OSCILLATING | MAX AMPS | | | | | | | |
|-------------------------------------|----------------|--------------------|------------------|------------------|--------------------|------------------|-----------|-------------|--------------------|------------------|-----------|------|--------------------|------------------|-----------|------|
| MOTOR | HP | 1/3 | | 1/3 | | 1/4 | | 1/4 | | | | | | | | |
| CFM Velocity Profile / Area Sq. Ft. | 20" | --- | --- | --- | --- | 5000 / 200 | 2.4 | 5000 / 200 | 2.4 | | | | | | | |
| | 24" | 6000 / 240 | 2.8 | 6000 / 240 | 2.8 | 6000 / 240 | 2.5 | 6000 / 240 | 2.5 | | | | | | | |
| | 30" | 7200 / 250 | 3.0 | 7200 / 250 | 3.0 | 7200 / 250 | 2.7 | 7200 / 250 | 2.7 | | | | | | | |
| WARRANTY | | 3 YEARS | | 3 YEARS | | 1 YEAR | | 1 YEAR | | | | | | | | |
| SIZE | TYPE of MOUNT | MFG CATALOG NUMBER | MFG MODEL NUMBER | LIST | MFG CATALOG NUMBER | MFG MODEL NUMBER | WT. (LBS) | LIST | MFG CATALOG NUMBER | MFG MODEL NUMBER | WT. (LBS) | LIST | MFG CATALOG NUMBER | MFG MODEL NUMBER | WT. (LBS) | LIST |
| 20" | Pedestal Mount | --- | --- | --- | --- | --- | --- | --- | 08681402 | ACU 20-P | 72 | 561 | 08681602 | ACU 20-PO | 76 | 593 |
| | Wall Mount | --- | --- | --- | --- | --- | --- | --- | 08681502 | ACU 20-W | 42 | 457 | 08681702 | ACU 20-WO | 46 | 476 |
| 24" | Pedestal Mount | 08745202 | UHP 24-PJR | 935 | 07990002 | UHP 24-P | 75 | 780 | 07962302 | ACU 24-P | 75 | 581 | 07964002 | ACU 24-PO | 79 | 881 |
| | Wall Mount | 08745402 | UHP 24-WJR | 789 | 07990202 | UHP 24-W | 45 | 637 | 07962402 | ACU 24-W | 45 | 484 | 07964102 | ACU 24-WO | 49 | 737 |
| 30" | Pedestal Mount | 08745302 | UHP 30-PJR | 956 | 07990102 | UHP 30-P | 73 | 806 | 07962802 | ACU 30-P | 73 | 597 | 07964202 | ACU 30-PO | 82 | 900 |
| | Wall Mount | 08745502 | UHP 30-WJR | 815 | 07990602 | UHP 30-W | 48 | 660 | 07962902 | ACU 30-W | 48 | 502 | 07964302 | ACU 30-WO | 52 | 755 |

TPI Industrial Specialty Circulator Heads

Features

- No cord-junction box provided for hard wiring
- Steel hub/spider aluminum paddle blades
- Coated steel guards
- Meets OSHA standards
- 1 year limited warranty
- Made in U.S.A. with domestic and foreign components

Motor Specifications

- All 1 Speed (except 277V which is 2 Speed)
- Totally enclosed, permanently lubricated
- Ball bearing



ACH-EX SERIES



Intertek

*Listing applies to 277V models only



IHP-H-277 Series



IHP-H-WD Series

WARNING: This product can expose you to chemicals including nickel which is known to the State of California to cause cancer, and chromium, which is known to the State of California to cause birth defects and/or reproductive harm. For more information go to www.P65Warnings.ca.gov.

Standard Models

| GENERAL DESCRIPTION | MFG MODEL NUMBER | MFG CATALOG NUMBER | SIZE | CFM* | | VELOCITY PROFILE CFM / Area Sq Ft | MOTOR | | | AMPS (HIGH) | | | | | WT. (LBS) | LIST |
|---|------------------|--------------------|------|------|------|--------------------------------------|-------|------|-----------------------|--------------|--------------|--------------|--------------|--------------|-----------|-------------|
| | | | | HIGH | LOW | | HP | RPM | VOLTS | 120v 1 ph | 240v 1 ph | 277v 1 ph | 240v 3 ph | 480v 3 ph | | |
| Hazardous Location Class I Group D Class II Group F & G Unassembled Head | ACH 24-EX1 | 08551902 | 24" | 4300 | 3900 | 6000 / 240 | 1/4 | 1725 | 120 or 240 1-phase | 5 | 2.6 | ---- | ---- | ---- | 66 | 1397 |
| | ACH 30-EX1 | 08552002 | 30" | 5400 | 4700 | 7200 / 250 | | | | | | | | | 69 | 1515 |
| | ACH 24-EX3 | 08552102 | 24" | 4300 | 3900 | 6000 / 240 | | | | | | | | | 66 | 1490 |
| | ACH 30-EX3 | 08552202 | 30" | 5400 | 4700 | 7200 / 250 | | | | | | | | | 69 | 1631 |
| 240V / 480V 3-Phase Unassembled Head | ACH 24-TE3 | 08552302 | 24" | 4300 | 3900 | 6000 / 240 | 1/4 | 1725 | 240 or 480 3-phase | ---- | ---- | ---- | 1.4 | 0.7 | 45 | 964 |
| | ACH 30-TE3 | 08552402 | 30" | 5400 | 4700 | 7200 / 250 | | | | | | | | | 48 | 986 |
| 277 Volt Assembled Head | IHP 24-H-277 | 08541302 | 24" | 4300 | 3900 | 6000 / 240 | 1/3 | 1125 | 277 1-phase | ---- | ---- | 1 | ---- | ---- | 40 | 677 |
| | IHP 30-H-277 | 08542202 | 30" | 5400 | 4700 | 7200 / 250 | | | | | | | | | 44 | 720 |
| Wash down rated 120V / 240V 1-Phase Assembled Head | IHP 20-H-WD | 08721902 | 20" | 3200 | | 5200 / 220 | 1/3 | 1725 | 120 or 240 1-phase | 4.5 | 2.2 | ---- | ---- | ---- | 46 | 1287 |
| | IHP 24-H-WD | 08541802 | 24" | 4300 | 3900 | 6000 / 240 | | | | | | | | | 48 | 1335 |
| | IHP 30-H-WD | 08541902 | 30" | 5400 | 4700 | 7200 / 250 | | | | | | | | | 52 | 1380 |

*Measured 2 feet from face of fan

Note: Wash down rated fan heads have heavy zinc coated guards - Use FDA white coated mounts shown on page 7 for food service applications

TPI Industrial Circulator Components

Standard Models

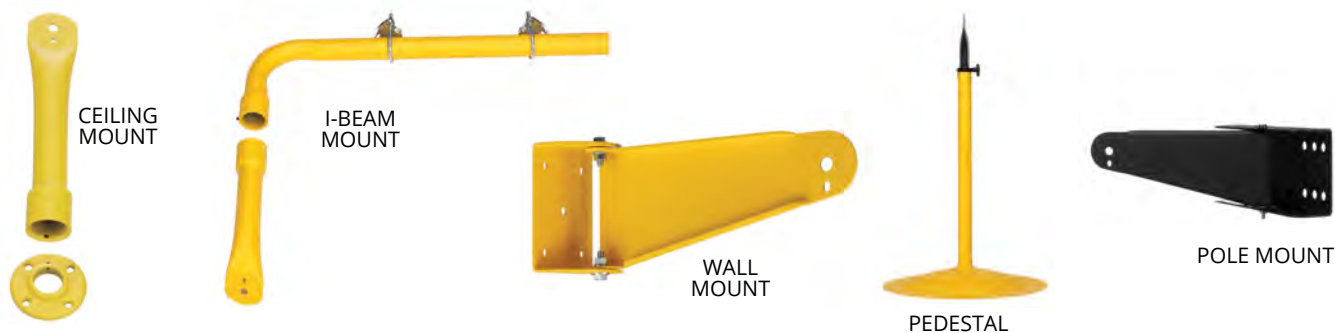
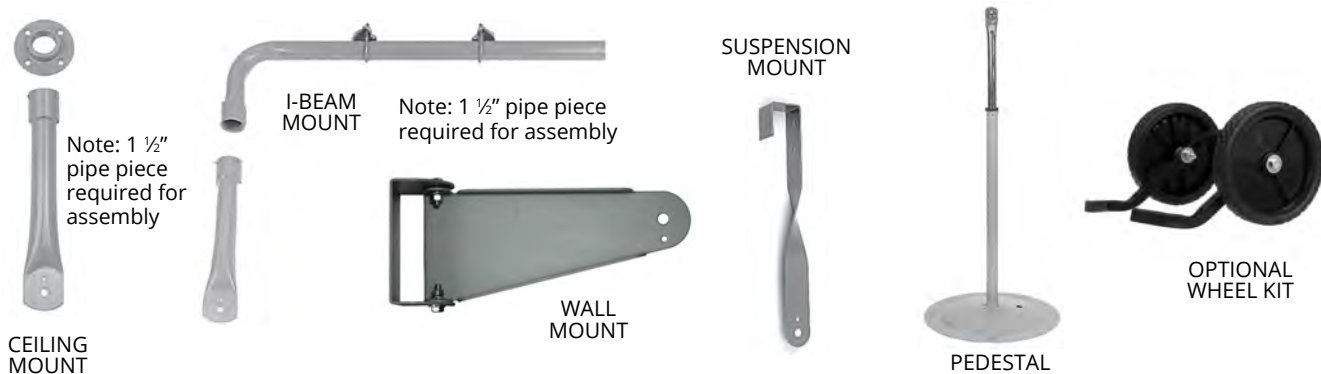

Product Specifications

- Pedestal pole adjusts the center of fan from 48" to 67" and bolts to 27" diameter steel dome base with 5 bolts
- I-beam mount & ceiling mount require 1 1/2" or longer pipe nipple for assembly (not supplied)
- Pole mount attaches to 4", 6", or 8" with U-bolts (not supplied)
- Wheel kit and pole mount have an all black textured powder coated finish

| TYPE | MFG CATALOG NUMBER | MFG MODEL NUMBER | LIST |
|--|--------------------|------------------|------------|
| YELLOW MOUNTS | | | |
| PEDESTAL POLE & BASE | 07960902 | HDM-P | 263 |
| WALL MOUNT | 07961002 | HDM-W | 105 |
| I-BEAM MOUNT | 07961102 | HDM-I | 200 |
| CEILING MOUNT | 07961202 | HDM-C | 114 |
| GRAY MOUNTS | | | |
| PEDESTAL POLE & BASE | 07961802 | ACM-P | 248 |
| WALL MOUNT | 07961902 | ACM-W | 96 |
| I-BEAM MOUNT | 07962002 | ACM-I | 188 |
| CEILING MOUNT | 07962102 | ACM-C | 124 |
| SUSPENSION MOUNT | 07962202 | ACM-S | 85 |
| POLE MOUNT | 08681802 | ACM-PM | 137 |
| WHEEL KIT | 08681302 | ACM-WK | 116 |
| FDA WHITE MOUNTS FOR USE WITH WASHDOWN FAN HEADS IN FOOD SERVICE APPLICATIONS | | | |
| PEDESTAL POLE & BASE | 08682502 | WACM-P | 245 |
| WALL MOUNT | 08682602 | WACM-W | 96 |

TPI Industrial & Commercial Air Circulators

What to know when ordering TPI Air Circulators:

- 1) **What is the operating voltage and phase?**
 - a. 120V (most common)
 - b. 120V or 240V
 - c. 277V
 - d. 240 or 480V (offered in 3-phase)
- 2) **How will you be mounting or operating this unit?**
 - a. Wall / Vertical Surface (Most Common)
 - b. Floor – Pedestal Mount
 - c. Pole Mount
 - d. Ceiling
 - e. Suspension Mount
 - f. I-Beam Mount
- 3) **What environment will this unit be operating in?**
 - a. Industrial – see TPI Series: HDH, IHP or ACH's
 - i. Dirty, dusty jobsites or harsh industrial environment
 - ii. Wet, high moisture, or wash down rated environment
 - iii. Hazardous Location – Class I Group D, Class II Groups F & G
 - b. Commercial – see TPI Series; CACU's
 - i. Clean areas or non-dusty environment
- 4) **Will you need the fan head to rotate?**
 - a. Oscillating
 - b. Non-Oscillating Fan Heads
- 5) **Do you want to order assembled fan heads?**
 - a. Assembled Fan Head
 - b. Unassembled Fan Head (ACU, UHP & CACU Series)
- 6) **Do you have a color preference?**
 - a. Safety Yellow – HDH Series
 - b. Industrial Textured Gray Finish (Most popular)
 - c. Black Semi-Gloss Powder Coated Finish (CACU-Series)

Air Circulators - Motor Comparisons

Commercial Motors - Open Vent Motors



- Offered in 1/4 HP & 1/3 HP
- Good output
- Open ventilated (air goes through the motor)
- Oscillating and Non-Oscillating
- Unassembled fan heads only
- 1-year limited warranty
- Ideal for Commercial Applications
 - Offered in 120V models

Commercial Fan Applications

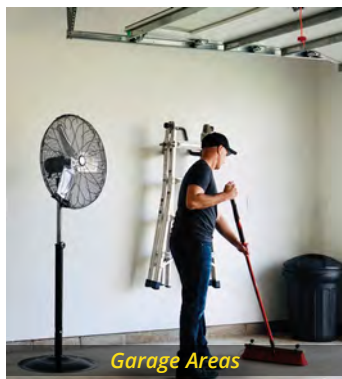

Industrial Motors - Totally Enclosed Motors (TEAO)



- Offered in 1/4 HP, 1/3 HP & 1/2 HP
- Higher quality and high CFP output
- Totally Enclosed Air Over (TEAO)
- Oscillating and Non-Oscillating
- Fully assembled fan heads
- No tools required to open grill assembly (retainer clips)
- 3-year warranty on 1/3 HP motors (5-year on 1/2 HP)
- Ideal for Commercial Applications
 - Offered in 120, 240, 277 & 480V models
 - Washdown and Hazardous Location Rated models

Industrial Fan Applications



TPI Commercial Circulators



These circulators should be used in clean and dry commercial applications - such as schools, shops, offices or warehouses.

Commercial Circulator

Motor, blades, guards, and mount are packed and shipped in a single UPS-able carton.



PEDESTAL MOUNT



WALL MOUNT



WARNING: This product can expose you to chemicals including nickel which is known to the State of California to cause cancer, and chromium, which is known to the State of California to cause birth defects and/or reproductive harm. For more information go to www.P65Warnings.ca.gov.

Features

- Black semi-gloss powder coated finish
- Pull chain switch
- SJT type 3 conductor, 9' long cord
- Coated steel guards with retaining clips
- Steel hub/spider aluminum paddle blades
- Pole adjusts center of fan from 43" to 60"
- Meets OSHA standards / 1-Year limited warranty
- Imported to TPI specifications

Motor Specifications

- 1-Phase
- 1/4 HP, 1/3 HP on HD Models
- Ball bearing
- Open ventilated
- 120V
- 3-Speed
- Permanently lubricated
- Permanent split capacitor

Standard Non-Oscillating Models

| MFG CATALOG NUMBER | MFG MODEL NUMBER | SIZE | HP | TYPE | MOUNT TYPE | CFM* | | | VELOCITY PROFILE CFM / Area Sq Ft | AMPS (HIGH) | WT. (LBS) | LIST |
|--------------------|------------------|------|------|-------------------|----------------|------|------|------|--------------------------------------|-------------|-----------|------------|
| | | | | | | HIGH | MED | LOW | | | | |
| 08778002 | CACU 20-P | 20" | 1/10 | Non - Oscillating | Pedestal Mount | 1780 | 1600 | 1420 | 3300 / 125 | 1.4 | 52 | 335 |
| 08778102 | CACU 20-W | | | | Wall Mount | | | | | | 48 | 302 |
| 08706202 | CACU 24-P | 24" | 1/4 | | Pedestal Mount | 3400 | 3100 | 2800 | 5400 / 220 | 2.3 | 63 | 494 |
| 08706402 | CACU 24-W | | | | Wall Mount | | | | | | 43 | 422 |
| 08697402 | CACU 30-P | 30" | 1/4 | | Pedestal Mount | 4200 | 3800 | 3500 | 6700 / 240 | 2.4 | 66 | 544 |
| 08706302 | CACU 30-W | | | | Wall Mount | | | | | | 46 | 436 |
| 08761702 | CACU 30-P-HD | 30" | 1/3 | | Pedestal Mount | 5000 | 4600 | 4200 | 7000 / 250 | 3.60 | 56 | 633 |

*Measured 2 feet from face of fan

Note: Stocked models may differ in appearance from photograph

TPI Commercial Oscillating Fans

Standard Oscillating Models



WALL MOUNT

| MFG CATALOG NUMBER | MFG MODEL NUMBER | SIZE | HP | TYPE | MOUNT TYPE | CFM* | | | VELOCITY PROFILE CFM / Area Sq Ft | AMPS | | | WT. (LBS) | LIST |
|--------------------|------------------|------|-----|-------------|----------------|------|------|------|--------------------------------------|------|------|------|-----------|------------|
| | | | | | | HIGH | MED | LOW | | HIGH | MED | LOW | | |
| 08748902 | CACU 24-PO | 24" | 1/4 | Oscillating | Pedestal Mount | 3200 | 3000 | 2800 | 5100 / 230 | 1.45 | 1.15 | 1.1 | 68 | 582 |
| 08749102 | CACU 24-WO | | | | Wall Mount | | | | | | | | 48 | 498 |
| 08749002 | CACU 30-PO | 30" | 1/4 | | Pedestal Mount | 4200 | 3800 | 3500 | 6700 / 250 | 2.0 | 1.8 | 1.6 | 70 | 611 |
| 08749202 | CACU 30-WO | | | | Wall Mount | | | | | | | | 51 | 541 |
| 08761802 | CACU 30-PO-HD | 30" | 1/3 | | Pedestal Mount | 5000 | 4600 | 4200 | 7000 / 250 | 3.60 | 3.02 | 2.94 | 64 | 783 |

Notes:

*Measured 2 feet from face of fan

Stocked models may differ in appearance from photograph - sizes are nominal
Units imported to TPI specifications.

WARNING: This product can expose you to chemicals including nickel which is known to the State of California to cause cancer, and chromium, which is known to the State of California to cause birth defects and/or reproductive harm. For more information go to www.P65Warnings.ca.gov.



36", 42", & 48" TPI Commercial Belt Drive Portable Blowers



WARNING: This product can expose you to chemicals including nickel which is known to the State of California to cause cancer, and chromium, which is known to the State of California to cause birth defects and/or reproductive harm. For more information go to www.P65Warnings.ca.gov.



Features

- Rotary switch
- SJT type cord - 3 conductor - 8' long
- Aluminum 4-paddle blade
- Spiral wire front and rear guards
- Black powder coated 20 gauge steel housing
- Stationary non-swivel housing
- 5" rubber wheels
- Meets OSHA standards / 1 Year limited warranty
- Imported to TPI specifications

Motor Specification

- 2-Speed
- 120V
- Ball bearing
- 1-Phase
- ODP type
- Permanently lubricated

| MFG CATALOG NUMBER | MFG MODEL NUMBER | MOTOR HP | CFM* | | VELOCITY PROFILE | MAX AMPS | WT. (LBS) | LIST |
|--------------------|------------------|----------|-------|-------|------------------|----------|-----------|-------------|
| | | | HIGH | LOW | CFM / Area Sq Ft | | | |
| 08734702 | CPB 36-B | 1/3 | 5,400 | 4,600 | 8600 / 300 | 4.8 | 82 | 770 |
| 08706602 | CPB 42-B | 1/2 | 7,600 | 6,700 | 12000 / 320 | 6.5 | 93 | 920 |
| 08722702 | CPB 48-B | 3/4 | 8,800 | 7,700 | 14000 / 500 | 9.0 | 129 | 1120 |

*Measured 2 feet from face of fan

Note: Photograph is a representation of stocked models. Actual model may vary in appearance

24", 30", & 36" TPI Commercial Direct Drive Portable Blowers



CPB 36-D



CPBS 30-D

Features

- Rotary or rocker switch
- SJT type cord - 3 conductor
- Spiral wire front and rear guards
- Black powder coated 20 gauge steel housing
- 5" rubber wheels
- Meets OSHA standards
- 1 Year limited warranty
- Imported to TPI specifications

Motor Specification

- 2-Speed
- 120 Volt
- Ball bearing
- 1-Phase
- Open ventilated
- Permanently lubricated

WARNING: This product can expose you to chemicals including nickel which is known to the State of California to cause cancer, and chromium, which is known to the State of California to cause birth defects and/or reproductive harm. For more information go to www.P65Warnings.ca.gov.

Standard Models

| MFG CATALOG NUMBER | MFG MODEL NUMBER | BASE TYPE | MOTOR HP | CFM* | | VELOCITY PROFILE | MAX AMPS | CORD LENGTH | SWITCH | BLADES | WT. (LBS) | LIST |
|--------------------|------------------|-----------|----------|-------|-------|------------------|----------|-------------|--------|----------|-----------|------------|
| | | | | HIGH | LOW | CFM / Area Sq Ft | | | | | | |
| 08753502 | CPB 30-D | Floor | 1/5 | 4,400 | 3,800 | 6700 / 250 | 3.6 | 6' | Rocker | Aluminum | 52 | 471 |
| 08710302 | CPBS 30-D | Swivel | 1/5 | 4,400 | 3,800 | 6700 / 250 | 3.6 | 6' | Rocker | Aluminum | 60 | 508 |
| 08722602 | CPB 36-D | Floor | 1/3 | 5,400 | 4,600 | 8500 / 300 | 3.6 | 10' | Rotary | Steel | 70 | 615 |
| 08770102 | CPBS 24-DHV | Swivel | 1/6 | 3,400 | 2,900 | 5400 / 240 | 2.4 | 9' | Rotary | Aluminum | 38 | 289 |

*Measured 2 feet from face of fan

Note: Photograph is a representation of stocked models. Actual model may vary slightly in appearance

30", 36", & 42" TPI Industrial Direct Drive Portable Blowers



STANDARD MODEL



SWIVEL MODEL



WARNING: This product can expose you to chemicals including nickel which is known to the State of California to cause cancer, and chromium, which is known to the State of California to cause birth defects and/or reproductive harm. For more information go to www.P65Warnings.ca.gov.

Features

- Comes in sizes 30", 36", & 42"
- Rocker switch
- SJT type 3 conductor, 12' long cord
- Aluminum, 3 paddle blade
- Spiral, wire front and rear guards
- Corrosion and dent proof high density polyethylene housing
- 36" & 42" swivel model rotates 112.5° in 22 1/2° increments and locks in place with a steel locking pin
- Meets OSHA standards
- 1 Year limited warranty
- Made in U.S.A.

Motor Specifications

- 120V, 1-Phase
- 36"-1/3HP 42"-1/2HP
- Ball bearing
- Permanent split capacitor
- 2-Speed on 30" model
- 1-Speed on 42" model
- Permanently lubricated
- Totally enclosed

Standard Models

| MFG CATALOG NUMBER | MFG MODEL NUMBER | FAN | | WHEEL SIZE | MOTOR HP | CFM* / RPM | | VELOCITY PROFILE | AMPS (HIGH) | WT. (LBS.) | LIST |
|--------------------|------------------|------|----------|------------|----------|-------------|-------------|------------------|-------------|-------------|-------------|
| | | SIZE | TYPE | | | HIGH | LOW | CFM / Area Sq Ft | | | |
| 08211002 | PBX 30-D | 30" | STANDARD | 8" | 1/4 | 4400 / 1100 | 3800 / 950 | 7200 / 250 | 2.7 | 65 | 860 |
| 08213602 | PBXS 30-D | 30" | SWIVEL | 10" | | | | | | 70 | 1150 |
| 08211102 | PBX 36-D | 36" | STANDARD | 8" | 1/3 | 6500 / 1040 | 5400 / 950 | 11500 / 320 | 5.5 | 82 | 1000 |
| 08213702 | PBXS 36-D | 36" | SWIVEL | 10" | | | | | | 110 | 1400 |
| 08211202 | PBX 42-D | 42" | STANDARD | 10" | 1/2 | 9,000 / 825 | 15000 / 340 | 7.9 | 102 | 1180 | |
| 08213802 | PBXS 42-D | 42" | SWIVEL | 10" | | | | | 128 | 1520 | |

*Measured 2 feet from face of fan

Note: Photograph is a representation of stocked models. Actual model may vary slightly in appearance

48" TPI Industrial Direct Drive Portable Blowers



SWIVEL MODEL



WARNING: This product can expose you to chemicals including nickel which is known to the State of California to cause cancer, and chromium, which is known to the State of California to cause birth defects and/or reproductive harm. For more information go to www.P65Warnings.ca.gov.

Features

- Corrosion and dent proof high density polyethylene housing
- Rocker switch
- SJT type 3 conductor, 12' long cord
- Steel, 2 paddle blade
- Spiral, wire front and rear guards
- 10" wheels
- Swivel model rotates 112.5° in 22 1/2° increments and locks in place with a steel locking pin
- Meets OSHA standards
- 1 Year limited warranty
- Made in U.S.A.

Motor Specifications

- 1-Phase
- 3/4 HP
- Ball bearing
- Permanent split capacitor
- 120V
- 1-Speed
- Permanently lubricated
- Totally enclosed

Features

| MFG CATALOG NUMBER | MFG MODEL NUMBER | SIZE | FAN TYPE | MOTOR HP | CFM* / RPM | VELOCITY PROFILE | AMPS (HIGH) | DIMENSIONS | | | WT. (LBS.) | LIST |
|--------------------|------------------|------|----------|----------|--------------|------------------|-------------|------------|------|------|------------|-------------|
| | | | | | | CFM / Area Sq Ft | | "H" | "D" | "W" | | |
| 07997802 | PB 48-D-OP | 48" | STANDARD | 3/4 | 11,800 / 825 | 14000 / 360 | 10.5 | 58.5 | 29 | 55.5 | 117 | 1987 |
| 07998002 | PBS 48-D-OP | 48" | SWIVEL | 3/4 | 11,800 / 825 | 14000 / 360 | 10.5 | ---- | ---- | ---- | 142 | 2268 |

*Measured 2 feet from face of fan

Note: Photograph is a representation of stocked models. Actual model may vary slightly in appearance

36", 42", & 48" TPI Industrial Belt Drive Portable Blowers

Features



STANDARD MODEL



CORD WRAP INCLUDED WITH STANDARD MODEL

⚠️ WARNING: This product can expose you to chemicals including nickel which is known to the State of California to cause cancer, and chromium, which is known to the State of California to cause birth defects and/or reproductive harm. For more information go to www.P65Warnings.ca.gov.



SWIVEL MODEL



- Comes in sizes 36", 42", and 48"
- Rocker switch on 120V, Single Phase models
- SJT type 3 conductor, 12' long cord on 120V, Single Phase models / no cord on dual voltage models
- 4 paddle blade: 36" PBX / PBSX & HL have aluminum blade; 42" & 48" PBX / PBSX have steel blade
- Spiral, wire front and rear guards
- Corrosion and dent proof high density polyethylene housing
- 8" wheels (36" model), 10" wheels (42" & 48" models)
- Swivel model rotates 112.5° in 22½° increments and locks in place with a steel locking pin
- External junction boxes on dual voltage models allow units to be wired for either voltage without removing guards
- Hazardous location models have explosion proof motors, metal housings, and external junction boxes rated for Class I, Group D and Class II, Groups E, F, & G
- Meets OSHA standards
- 1 year limited warranty
- Made in U.S.A.

Motor Specifications

- 1-Speed
- Ball bearing
- Permanently lubricated

Standard Models

| MOTOR LISTING | SIZE | MOTOR | | | | CFM** | VELOCITY PROFILE | STANDARD MODEL | | | | SWIVEL MODEL | | | |
|---------------|------|-----------------------------|-----|-----|------------|--------|------------------|--------------------|------------------|-----------|-------------|--------------------|------------------|-----------|-------------|
| | | TYPE | HP | RPM | AMPS | | CFM / Area Sq Ft | MFG CATALOG NUMBER | MFG MODEL NUMBER | WT. (LBS) | LIST | MFG CATALOG NUMBER | MFG MODEL NUMBER | WT. (LBS) | LIST |
| | 36" | 120 V 1 PH ODP | 1/2 | 500 | 8.0 | 6,900 | 14000 / 360 | 08211402 | PBX 36-B | 120 | 1220 | 08213302 | PBXS 36-B | 145 | 1600 |
| | 42" | | 3/4 | 430 | 11.0 | 10,600 | 17500 / 420 | 08211502 | PBX 42-B | 135 | 1500 | 08213402 | PBXS 42-B | 160 | 1820 |
| | 48" | | 1 | 390 | 15.0 | 14,400 | 23500 / 550 | 08211602 | PBX 48-B | 155 | 1580 | 08213502 | PBXS 48-B | 180 | 1920 |
| | 36" | 240/480 V 3 PH ODP | 1/2 | 500 | 2.3 / 1.1 | 6,900 | 14000 / 360 | 08508602 | PB 36-B-3 | 127 | 1962 | 08509202 | PBS 36-B-3 | 152 | 2313 |
| | 42" | | 3/4 | 430 | 3.3 / 1.5 | 10,600 | 17500 / 420 | 08508702 | PB 42-B-3 | 143 | 2201 | 08509302 | PBS 42-B-3 | 168 | 2744 |
| | 48" | | 1 | 390 | 3.8 / 1.9 | 14,400 | 23500 / 550 | 08508802 | PB 48-B-3 | 164 | 2504 | 08509402 | PBS 48-B-3 | 189 | 2888 |
| --- | 36" | 120/240 V 1 PH EXP | 1/2 | 500 | 7.8 / 3.9 | 6,900 | 14000 / 360 | 08508902 | PB 36-B-HL* | 135 | 2958 | 08509502 | PBS 36-B-HL | 160 | 3264 |
| | 42" | | 3/4 | 430 | 10.8 / 5.4 | 10,600 | 17500 / 420 | 08509002 | PB 42-B-HL* | 150 | 3112 | 08509602 | PBS 42-B-HL | 175 | 3720 |
| | 48" | | 1 | 390 | 13.2 / 6.6 | 14,400 | 23500 / 550 | 08509102 | PB 48-B-HL* | 173 | 3651 | 08509702 | PBS 48-B-HL | 198 | 4027 |

**Measured 2 feet from face of fan *Models have no listing.

Note: Products listed in this section are custom built and subject to 100% cancellation/restocking charges.

Note: Photograph is a representation of stocked models. Actual model may vary slightly in appearance.

TPI Industrial Direct Drive Suspension Blowers

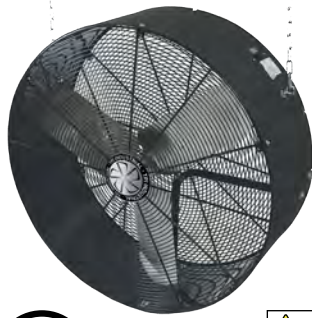

Features

- On-Off rocker switch
- SJT type 3 conductor, 12' long cord
- Aluminum blade
- Powder coated spiral wire front and rear guards
- Corrosion and dent proof high density polyethylene housing
- Meets OSHA standards
- 1 year limited warranty
- Mounting chain not included
- Made in U.S.A.

Motor Specifications

- 120V, 1-Phase
- Ball bearing
- Permanent split capacitor
- 2-Speed on 30" & 36" model
- 1-Speed on 42" model
- Permanently lubricated



WARNING: This product can expose you to chemicals including nickel which is known to the State of California to cause cancer, and chromium, which is known to the State of California to cause birth defects and/or reproductive harm. For more information go to www.P65Warnings.ca.gov.

Standard Models

| SIZE | MOTOR HP | MFG CATALOG NUMBER | MFG MODEL NUMBER | CFM* | | VELOCITY PROFILE | RPM HIGH | AMPS HIGH | WT. (LBS) | LIST |
|------|----------|--------------------|------------------|-------|-------|------------------|----------|-----------|-----------|-------------|
| | | | | HIGH | LOW | CFM / Area Sq Ft | | | | |
| 30" | 1/4 | 08213002 | SBX 30-D | 4,400 | 3,800 | 7200 / 250 | 1050 | 2.7 | 58 | 860 |
| 36" | 1/3 | 08213102 | SBX 36-D | 6,500 | 5,400 | 11500 / 320 | 1050 | 5.5 | 70 | 950 |
| 42" | 1/2 | 08213202 | SBX 42-D | 9,000 | | 15000 / 340 | 825 | 7.9 | 99 | 1120 |

*Measured 2 feet from face of fan

TPI Industrial Belt Drive Suspension Blowers



Features

- On-Off rocker switch on 120V, 1-Phase models
- SJT type 3 conductor, 12' long cord on 120V, 1 phase models
- No cord on dual voltage models
- Aluminum blade: SBX 36-B, SB 36-B-HL, SB 42-B-HL, SB 48-B-HL
- Steel blade: SBX 42-B, SBX 48-B
- Corrosion and dent proof high density polyethylene housing
- Powder coated spiral wire front and rear guards
- Meets OSHA standards
- 1 year limited warranty
- Mounting chain not included
- Made in U.S.A.

Motor Specifications

- 120V, 1-Phase
- Ball bearing
- Permanent split capacitor
- 2-Speed on 30" & 36" model
- 1-Speed on 42" model
- Permanently lubricated

External junction boxes on dual voltage models allow units to be wired for either voltage without removing guards.

Hazardous Location models have explosion proof motors and external junction boxes rated for Class I, Group D, & Class II, Groups E, F & G., (Metal housing and no switch)

WARNING: This product can expose you to chemicals including nickel which is known to the State of California to cause cancer, and chromium, which is known to the State of California to cause birth defects and/or reproductive harm. For more information go to www.P65Warnings.ca.gov.

Standard Models

| MFG CATALOG NUMBER | MFG MODEL NUMBER | SIZE | MOTOR | | CFM** | VELOCITY PROFILE | RPM | AMPS | WT. (LBS) | LIST |
|--------------------|------------------|------|------------------------|-----|--------|------------------|-----|------------|-----------|-------------|
| | | | TYPE | HP | | CFM / Area Sq Ft | | | | |
| 08212702 | SBX 36-B | 36" | 115 V, 1 PH, ODP | 1/2 | 6,900 | 14000 / 360 | 500 | 8 | 120 | 1160 |
| 08212802 | SBX 42-B | 42" | | 3/4 | 10,600 | 17500 / 420 | 430 | 11 | 135 | 1360 |
| 08212902 | SBX 48-B | 48" | | 1 | 14,400 | 23500 / 550 | 390 | 15 | 155 | 1420 |
| 08509802 | SB 36-B-3 | 36" | 230 / 460 V, 3 PH, ODP | 1/2 | 6,900 | 14000 / 360 | 500 | 2.3 / 1.1 | 127 | 1871 |
| 08509902 | SB 42-B-3 | 42" | | 3/4 | 10,600 | 17500 / 420 | 430 | 3.3 / 1.5 | 143 | 2265 |
| 08510002 | SB 48-B-3 | 48" | | 1 | 14,400 | 23500 / 550 | 390 | 3.8 / 1.9 | 164 | 2382 |
| 08510102 | SB 36-B-HL* | 36" | 115 / 230 V, 1 PH, EXP | 1/2 | 6,900 | 14000 / 360 | 500 | 7.8 / 3.9 | 135 | 2958 |
| 08510202 | SB 42-B-HL* | 42" | | 3/4 | 10,600 | 17500 / 420 | 430 | 10.8 / 5.4 | 150 | 3363 |
| 08510302 | SB 48-B-HL* | 48" | | 1 | 14,400 | 23500 / 550 | 390 | 13.2 / 6.6 | 173 | 3651 |

Note: Products listed in this section are custom built and subject to 100% cancellation/restocking charges. Note: Photograph is a representation of stocked models. Actual model may vary slightly in appearance.

*Models have no listing. **Measured 2 feet from face of fan

TPI Industrial Mini-Blowers



FLOOR MODEL



YOKE MOUNTED MODEL

- ** USE IN DIRTY OR DUSTY ENVIRONMENTS
- ** FLOOR MODEL OR YOKE MOUNT AVAILABLE.
- ** BOLT TO ANY SURFACE OR USE WITH OPTIONAL WALL/CEILING MOUNT.

Features

- Floor models have rotary switch
- Yoke mounted models have pull chain switch
- SJT type 3 conductor, 10' long cord
- Aluminum blade
- Spiral, wire front and rear guards
- Corrosion and dent proof high density polyethylene housing
- Meets OSHA standards
- 1 year limited warranty
- Made in U.S.A. with domestic and foreign components



MBM-W (Optional Wall/Ceiling Mount)



WARNING: This product can expose you to chemicals including nickel which is known to the State of California to cause cancer, and chromium, which is known to the State of California to cause birth defects and/or reproductive harm. For more information go to www.P65Warnings.ca.gov.

Motor Specifications

- 1-Phase
- 1/4 HP
- Ball bearing
- Totally enclosed
- 120V
- 2-Speed
- Permanently lubricated
- Permanent split capacitor

Standard Models

| MFG CATALOG NUMBER | MFG MODEL NUMBER | FAN | | CFM* / RPM | | VELOCITY PROFILE CFM / Area Sq Ft | DIMENSIONS | | | AMPS (High) | WT. (LBS) | LIST |
|--------------------|------------------|--|------|-------------|-------------|--------------------------------------|------------|---------|---------|-------------|-----------|------|
| | | TYPE | SIZE | HIGH | LOW | | "H" | "W" | "D" | | | |
| 08743502 | MB 24-DF | FLOOR STYLE | 24" | 3300 / 1140 | 2900 / 1070 | 5200 / 240 | 29 1/2" | 28 1/2" | 14 1/4" | 1.8 | 52 | 845 |
| 08743602 | MB 24-DY | YOKE STYLE | | | | | 29" | 28 1/2" | 14 1/4" | | | |
| 08743702 | MB 30-DF | FLOOR STYLE | 30" | 4400 / 1040 | 3900 / 730 | 7000 / 250 | 38 1/2" | 37 1/2" | 14 1/2" | 2.7 | 58 | 933 |
| 08743802 | MB 30-DY | YOKE STYLE | | | | | 38" | 37 1/2" | 14 1/2" | | | |
| 07989002 | MBM-W | OPTIONAL WALL/CEILING MOUNT FOR YOKE STYLE MINI-BLOWER | | | | | | | | | 4 | 171 |

*Measured 2 feet from face of fan

TPI Industrial Heavy Duty Square Belt Drive Portable Blowers



4" CASTERS



WARNING: This product can expose you to chemicals including nickel which is known to the State of California to cause cancer, and chromium, which is known to the State of California to cause birth defects and/or reproductive harm. For more information go to www.P65Warnings.ca.gov.

Features

- On-Off rocker switch
- SJT type 3 conductor, 12' long cord
- Steel blade
- Permanently lubricated bearings on blade drive shaft
- Powder coated front and rear guards
- Powder coated 20 gauge venturi
- 18 gauge galvanized steel housing
- Meets OSHA standards / 1 Year limited warranty
- Made in U.S.A.

Motor Specifications

- 1-Phase
- Ball bearing
- Drip proof motor
- 120V
- 1-Speed
- Permanently lubricated
- 1/2" Shaft

Standard Models

| SIZE | MFG CATALOG NUMBER | MFG MODEL NUMBER | MOTOR | | | CFM* | VELOCITY PROFILE CFM / Area Sq Ft | DIMENSIONS | | | WT. (LBS) | LIST |
|------|--------------------|------------------|-------|------|------|--------|--------------------------------------|------------|--------|---------|-----------|------|
| | | | HP | RPM | AMPS | | | "H" | "W" | "D" | | |
| 36" | 08683602 | PCBT 36-B | 1/2 | 1725 | 8.0 | 6,900 | 14,000 / 360 | 48 1/4" | 40.38" | 22 1/2" | 120 | 2157 |
| 42" | 08683702 | PCBT 42-B | 3/4 | | 11.0 | 10,600 | 17,500 / 420 | 56 1/2" | 48.38" | 22 1/2" | 140 | 2802 |
| 48" | 08683802 | PCBT 48-B | 1 | | 15.0 | 14,400 | 23,500 / 550 | 62 1/2" | 54.38" | 18 1/2" | 185 | 3407 |

*Measured 2 feet from face of fan



DIRECT DRIVE- SINGLE SPEED HIGH VELOCITY BLOWERS

THREE SIZES TO SELECT FROM:
18", 24" or 30" housing diameters



Features

- ETL C/US listed for indoor spot cooling applications
- 20-gauge all steel construction housing with gray epoxy powder coated finish
- Heavy-duty yoke mounting bracket design with 2" square steel tubing frame
- Direct drive Totally Enclosed Air-Over (TEAO) motor generating up to 9,000-CFM's
- Single speed, ball bearing, with split capacitor, permanently lubricated, TEAO motor operates on 60HZ and 1725-RPMs, and requires hard-wired connection to the supplied electrical enclosure located on the motor housing
- Aluminum 3-paddle blade system with steel hub and cast aluminum spider connections
- Non-Oscillating fan heads offered 18", 24" & 30" diameter sizes
- 2-year motor warranty

Benefits

- Housing designed for all types of air circulating applications to provide directional - high velocity air flow.
- Built-in rotating design allows the supplied mounting bracket to pivot 120° in (9) adjustment settings at 15° variations.
- Front & rear spiral wound grills are OSHA approved and have a black powder coated finish.
- All units are shipped fully assembled and ready for hard-wired connections
- TEAO motor has a Class B rating, with automatic thermal protection and ball bearing design for harsh environments; rated up to 115°F max. ambient temperature.
- Single and three phase options available in 120, 277 & 480-Volt.

All Steel Structure

2" square tubing

Adjustable bracket up to 120°

HV-24

20-gauge steel frame with welded venturi design on intake & discharge ends

Specifications

- 1-Speed
- 1 Phase, 120V, 208/240V, 277V or 480V
- 3-Phase, 480V
- Ball bearing
- Totally enclosed, air over
- Permanent split capacitor/lubricate
- 1/2" Motor Shaft

Applications

Units are ideal for warehouse, material handling, and high-shelf areas for directing high volumes of air flow down aisles, loading dock areas, conveyor systems, processing centers, workstations, jobsite, and all types of industrial operations for rugged environments.



HV-1 dock arm mount accessory plus HV-18 fan head

HV-30



HV-1

HV-3 Wall/Column Mount Accessory plus HV-30 Fan Head



TPI Industrial High Velocity Blowers

Standard Models

| SIZE | MFG CATALOG NUMBER | MFG MODEL NUMBER | VOLTS | PH | AMPS (High) | HP | WATTS | RPM | CFM* | VELOCITY PROFILE | BLADE DIA. | DIMENSIONS (in.) | | | WT. (lbs.) | LIST |
|------|--------------------|------------------|-------------|----|-------------|-----|-------|------|------|------------------|------------|------------------|------|------|------------|------|
| | | | | | | | | | | CFM/Area Sq. Ft. | | L | W | H | | |
| 18" | 08195602 | HV-18-120V | 120 | 1 | 3.4 | 1/2 | 373 | 1725 | 3000 | 5000 / 175 | 16" | 13.5 | 27.4 | 26 | 45 | 1323 |
| | 08195702 | HV-18-208/240V | 208/240 | 1 | 1.9 | | | | | | | | | | | |
| | 08195802 | HV-18-277V | 277 | 1 | 1.5 | | | | | | | | | | | |
| | 08195902 | HV-18-480V | 480 | 1 | 1.0 | | | | | | | | | | | |
| | 08197202 | HV-18-480V-3 | 208-230/460 | 3 | 1.4 / 0.8 | | | | | | | | | | | 1517 |
| 24" | 08196002 | HV-24-120V | 120 | 1 | 3.8 | 1/2 | 373 | 1725 | 5290 | 8500 / 275 | 22" | 13.5 | 33.3 | 31.4 | 58 | 1516 |
| | 08196102 | HV-24-208/240V | 208/240 | 1 | 2.1 | | | | | | | | | | | |
| | 08196202 | HV-24-277V | 277 | 1 | 1.7 | | | | | | | | | | | |
| | 08196302 | HV-24-480V | 480 | 1 | 1.1 | | | | | | | | | | | |
| | 08197302 | HV-24-480V-3 | 208-230/460 | 3 | 1.5 / 0.8 | | | | | | | | | | | 1833 |
| 30" | 08196402 | HV-30-120V | 120 | 1 | 7.6 | 1 | 746 | 1700 | 9000 | 14250 / 375 | 28" | 16 | 38.9 | 39 | 85 | 2191 |
| | 08196502 | HV-30-208/240V | 208/240 | 1 | 4.3 | | | | | | | | | | | |
| | 08196602 | HV-30-277V | 277 | 1 | 3.2 | | | | | | | | | | | |
| | 08196702 | HV-30-480V | 480 | 1 | 1.6 | | | | | | | | | | | |
| | 08197402 | HV-30-480V-3 | 208-230/460 | 3 | 3.4 / 1.6 | | | | | | | | | | | 2688 |

*Measured 2' from face of fan; Velocity is the highest recorded CFM

Dimensions:

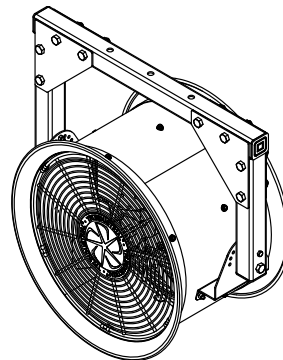
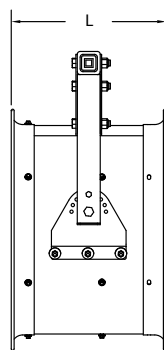
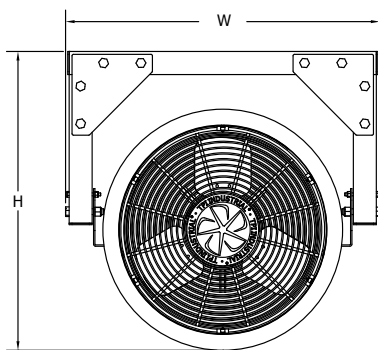

Dock Swing Arm - 24" Reach



Wall/Column Mount



HV-2 (22" reach)
or
HV-3 (25" reach)

Accessory Models

| MFG CATALOG NUMBER | MFG MODEL NUMBER | TYPE | FITS MODEL SERIES | LIST |
|--------------------|------------------|---------------------|-------------------|------|
| 08197502 | HV-1 | Dock Arm, 24" Reach | HV-18 | 193 |
| 08197602 | HV-2 | Wall / Column Mount | HV-18 & HV-24 | 276 |
| 08197702 | HV-3 | Wall / Column Mount | ALL | 287 |
| 08199002 | HV-4-18 | Low Stand | HV-18 | 600 |
| 08199102 | HV-4-24 | | HV-24 | 663 |
| 08199202 | HV-4-30 | | HV-30 | 725 |
| 08199302 | HV-5-18 | Medium Stand | HV-18 | 932 |
| 08199402 | HV-5-24 | | HV-24 | 1026 |
| 08199502 | HV-5-30 | | HV-30 | 1177 |
| 08199602 | HV-6-18 | High Stand | HV-18 | 1085 |
| 08199702 | HV-6-24 | | HV-24 | 1233 |
| 08199802 | HV-6-30 | | HV-30 | 1380 |
| 08199902 | HV-7-DC-1 | Disconnect Switch | 1-Phase | 634 |
| 08200002 | HV-7-DC-3 | | 3-Phase | 662 |
| 08209802 | HV-8 | Caster Kit (Qty.4) | ALL Heads/Stands | 205 |



Image Shown Includes

HV-24 (Fan Head)
HV-5-24 (Medium Stand)
HV-8 (Caster Kit)

Note: All items must be ordered separately.

Note : Stands do not include casters

Contact TPI customer Service for additional cost for mounting fan to the stand and wiring the disconnect prior to shipping.

TPI Industrial Heavy Duty Direct Drive Blowers

WARNING: This product can expose you to chemicals including nickel which is known to the State of California to cause cancer, and chromium, which is known to the State of California to cause birth defects and/or reproductive harm. For more information go to www.P65Warnings.ca.gov.



LOW STAND



MEDIUM STAND



HIGH STAND

Features

- Totally enclosed and explosion proof motors
- Explosion proof motors are Class 1, Div 1, Group D and Class 2, Div 1, Groups F & G
- Cast Aluminum props
- 14 gauge steel body and stand
- Acid resistant coating available
- Baked enamel coating
- 360° Swivel on high and medium stand units
- Meets federal OSHA requirements
- 1 year limited warranty

NOTE:

Single phase motors are field convertible 115V / 230V
 Three phase motors are field convertible 230V / 460V
 Motors are set to lower voltage at the factory unless a request is made at time of order to set to the higher voltage

Standard Models

| SIZE | MFG MODEL NUMBER | HP | RPM | CFM | DB's @ 10' | WT. (LBS) | | | LIST | | | | | | | | | | | |
|-----------------------|------------------|-----|------|-------|------------|-----------|------|------|------|-------|------|-------|------|-------|------|-------|------|-------|------|-------|
| | | | | | | STAND | | | TEC | | EXP | | TEC | | EXP | | TEC | | EXP | |
| | | | | | | LOW | MED | HIGH | 1PH | 3PH | 1PH | 3PH | 1PH | 3PH | 1PH | 3PH | 1PH | 3PH | 1PH | 3PH |
| MODEL NUMBER SUFFIXES | | | | | | | | | -L | -L-3 | -L | -L-3 | -M | -M-3 | -M | -M-3 | -H | -H-3 | -H | -H-3 |
| 18" | MCD18-1/4 | 1/4 | 1725 | 3050 | 74 | 103 | 145 | 210 | 3519 | 3503 | 4050 | 4136 | 4338 | 4322 | 4859 | 4958 | 4732 | 4718 | 5268 | 10659 |
| | MCD18-1/3 | 1/3 | 1725 | 3450 | 76 | 105 | 150 | 215 | 3638 | 3668 | 4329 | 4508 | 4454 | 4480 | 5145 | 5333 | 4853 | 4877 | 5550 | 10045 |
| | MCD18-1 | 1 | 1725 | 4600 | 77 | 117 | 165 | 230 | 4104 | 3953 | 4868 | 4958 | 4931 | 4769 | 5678 | 5777 | 5326 | 5168 | 6083 | 6174 |
| 24" | MCD24-1/4 | 1/4 | 1725 | 5200 | 80 | 115 | 165 | 230 | 3600 | 3588 | 4120 | 4221 | 4523 | 4517 | 5041 | 5145 | 4846 | 4628 | 5363 | 5466 |
| | MCD24-1/3 | 1/3 | 1140 | 5300 | 74 | 126 | 175 | 250 | 4177 | 4221 | 5311 | 5372 | 5099 | 5145 | 6232 | 6296 | 5422 | 5261 | 6555 | 6615 |
| | MCD24-1/2 | 1/2 | 1725 | 6000 | 80 | 120 | 170 | 240 | 3902 | 3917 | 4713 | 4628 | 4824 | 4841 | 5632 | 5550 | 5145 | 4958 | 5955 | 5873 |
| | MCD24-3/4 | 3/4 | 1140 | 6900 | 74 | 140 | 190 | 260 | 4981 | 4508 | 5647 | 5493 | 5904 | 5438 | 6572 | 6414 | 6224 | 5550 | 6893 | 6735 |
| | MCD24-1 | 1 | 1725 | 7400 | 82 | 130 | 180 | 250 | 4233 | 4080 | 4986 | 5077 | 5154 | 5003 | 5909 | 6000 | 5476 | 5116 | 6232 | 6322 |
| | MCD24-1 1/2 | 1.5 | 1725 | 8200 | 84 | 137 | 190 | 255 | 4472 | 4277 | 6609 | 5432 | 5394 | 5205 | 7531 | 6353 | 5716 | 5318 | 7853 | 6674 |
| | MCD24-3 | 3 | 1725 | 10500 | 87 | 160 | 210 | 270 | ---- | 4668 | ---- | 5904 | ---- | 5588 | ---- | 6833 | ---- | 5709 | ---- | 7147 |
| 30" | MCD30-1/3 | 1/3 | 1140 | 6900 | 80 | 150 | 205 | 260 | 4583 | 4628 | 5716 | 5777 | 5595 | 5641 | 6729 | 6796 | 6000 | 6045 | 7125 | 7194 |
| | MCD30-1/2 | 1/2 | 1725 | 8900 | 86 | 141 | 195 | 250 | 4312 | 4329 | 5123 | 5041 | 5333 | 5348 | 6141 | 6063 | 5733 | 5746 | 6539 | 6458 |
| | MCD30-3/4 | 3/4 | 1140 | 10400 | 80 | 210 | 260 | 320 | 5275 | 4809 | 5934 | 5782 | 6284 | 5821 | 6953 | 6801 | 6684 | 6218 | 7349 | 7202 |
| | MCD30-1 | 1 | 1140 | 11200 | 81 | 200 | 260 | 310 | 6322 | 5072 | 7540 | 6000 | 7343 | 6089 | 8558 | 7012 | 7739 | 6487 | 8954 | 7410 |
| | MCD30-1 1/2 | 1.5 | 1725 | 12000 | 92 | 200 | 250 | 310 | 4868 | 4674 | 7006 | 5829 | 5880 | 5695 | 8026 | 6848 | 6277 | 6089 | 8422 | 7246 |
| | MCD30-2 | 2 | 1140 | 14000 | 84 | 225 | 270 | 330 | ---- | 5422 | ---- | 6750 | ---- | 6442 | ---- | 7770 | ---- | 6840 | ---- | 8168 |
| | MCD30-3 | 3 | 1725 | 16000 | 94 | 220 | 265 | 325 | ---- | 4964 | ---- | 6203 | ---- | 5985 | ---- | 7222 | ---- | 6386 | ---- | 7614 |
| 36" | MCD36-1 | 1 | 1140 | 13000 | 82 | 250 | 320 | 375 | 7140 | 5888 | 8356 | 6811 | 8394 | 7147 | 9614 | 8072 | 8657 | 7404 | 9870 | 8327 |
| | MCD36-1 1/2 | 1.5 | 1725 | 14850 | 88 | 250 | 320 | 375 | 5647 | 5454 | 7784 | 6609 | 6902 | 6705 | 9037 | 7861 | 7162 | 6965 | 9301 | 8124 |
| | MCD36-2 | 2 | 1140 | 17500 | 82 | 255 | 325 | 380 | ---- | 6024 | ---- | 7357 | ---- | 7283 | ---- | 8611 | ---- | 7540 | ---- | 8873 |
| | MCD36-3 | 3 | 1725 | 18500 | 90 | 260 | 330 | 390 | ---- | 5754 | ---- | 6990 | ---- | 7006 | ---- | 8249 | ---- | 7267 | ---- | 8505 |
| | MCD36-5 | 5 | 1725 | 23000 | 94 | 260 | 330 | 390 | ---- | 5852 | ---- | 7208 | ---- | 7102 | ---- | 8460 | ---- | 7357 | ---- | 8715 |
| 42" | MCD42-2 | 2 | 1140 | 19500 | 85 | 315 | 415 | 565 | ---- | 6916 | ---- | 8249 | ---- | 8249 | ---- | 9578 | ---- | 8776 | ---- | 10110 |
| | MCD42-5 | 5 | 1725 | 27000 | 98 | 320 | 420 | 570 | ---- | 6735 | ---- | 8100 | ---- | 8072 | ---- | 9427 | ---- | 8603 | ---- | 9968 |
| 48" | MCD48-5 | 5 | 1140 | 32000 | 92 | 500 | 620 | 710 | ---- | 9136 | ---- | 11377 | ---- | 10605 | ---- | 12847 | ---- | 11540 | ---- | 13783 |
| | MCD48-7 1/2 | 7.5 | 1140 | 37000 | 105 | 625 | 745 | 835 | ---- | 10605 | ---- | 14317 | ---- | 12077 | ---- | 15787 | ---- | 13012 | ---- | 16717 |
| | MCD48-10 | 10 | 1140 | 41000 | 105 | 682 | 800 | 890 | ---- | 12411 | ---- | 15720 | ---- | 13881 | ---- | 17180 | ---- | 14813 | ---- | 18119 |
| 60" | MCD60-3 | 3 | 690 | 35000 | 87 | 690 | 855 | 965 | ---- | 19470 | ---- | ---- | ---- | 22243 | ---- | ---- | ---- | 22880 | ---- | ---- |
| | MCD60-5 | 5 | 690 | 45000 | 87 | 730 | 895 | 1005 | ---- | 21897 | ---- | ---- | ---- | 24663 | ---- | ---- | ---- | 25309 | ---- | ---- |
| | MCD60-7 1/2 | 7.5 | 870 | 47000 | 90 | 945 | 1110 | 1220 | ---- | 18351 | ---- | ---- | ---- | 21118 | ---- | ---- | ---- | 21756 | ---- | ---- |
| | MCD60-10 | 10 | 870 | 57200 | 91 | 1035 | 1200 | 1310 | ---- | 22842 | ---- | ---- | ---- | 25610 | ---- | ---- | ---- | 26254 | ---- | ---- |
| | MCD60-15 | 15 | 870 | 60750 | 92 | 1080 | 1245 | 1355 | ---- | 29876 | ---- | ---- | ---- | 32641 | ---- | ---- | ---- | 33286 | ---- | ---- |

Manual Starter Switches

| MFG MODEL NUMBER | | H.P. RATING | LIST PRICE | |
|------------------|------------|-------------|------------|------|
| 1 PH | 3 PH | | TEC | |
| | | | 1 PH | 3 PH |
| SW-1/4 | SW-1/4-3 | 1/4-1/3 | 679 | 1619 |
| SW-1/2 | SW-1/2-3 | 1/2-3/4 | 679 | 1619 |
| SW-1 | SW-1-3 | 1 | 679 | 1619 |
| SW-1 1/2 | SW-1 1/2-3 | 1.5 | 1592 | 1619 |
| ---- | SW-2-3 | 2 | ---- | 1619 |
| ---- | SW-3-3 | 3 | ---- | 1619 |
| ---- | SW-5-3 | 5 | ---- | 1619 |
| ---- | SW-7 1/2-3 | 7.5 | ---- | 1536 |

Polyolifin Casters

| MFG MODEL NUMBER | FAN SIZE | WHEEL SIZE | WT. (LBS) | LIST |
|------------------|-----------|------------|-----------|------|
| CAS - 18 | 18" - 30" | 4" | 10 | 651 |
| CAS - 48 | 36" - 48" | 5" | 14 | 917 |

(FOR LOW & MEDIUM STAND)
 4 CASTERS - 2 LOCKING

Note: Products listed in this section are custom built and subject to 100% cancellation/restocking charges

TPI Industrial Heavy Duty Permanent Mount Direct Drive Blowers



1-WAY SWIVEL



2-WAY SWIVEL

⚠ WARNING: This product can expose you to chemicals including nickel which is known to the State of California to cause cancer, and chromium, which is known to the State of California to cause birth defects and/or reproductive harm. For more information go to www.P65Warnings.ca.gov.

Features

- Front and rear spiral guards
- Explosion proof motors are Class 1, Div 1, Group D and Class 2, Div 1, Groups F & G
- Cast aluminum props
- 14 gauge steel body and stand
- Meets federal OSHA requirements
- 1 year limited warranty

NOTE:

Single Phase motors are field convertible 115V / 230V
Three Phase motors are field convertible 230V / 460V
Motors are set to lower voltage at the factory unless a request is made at time of order to set to the higher voltage

Standard Models

| BLADE SIZE | MFG MODEL NUMBER | HP | RPM | CFM | DB'S @ 10' | WT. (LBS) | | LIST PRICE | | | | | | | |
|-----------------------|------------------|-----|------|-------|------------|-----------|------|--------------|------|------|------|--------------|------|-------|-------|
| | | | | | | | | 1-WAY SWIVEL | | | | 2-WAY SWIVEL | | | |
| | | | | | | TEC | | EXP | | TEC | | EXP | | | |
| | | | | | | 1PH | 3PH | 1PH | 3PH | 1PH | 3PH | 1PH | 3PH | | |
| MODEL NUMBER SUFFIXES | | | | | | -T | -T-3 | -T | -T-3 | -S | -S-3 | -S | -S-3 | | |
| 18" | MCD18-1/4 | 1/4 | 1725 | 3050 | 74 | 130 | 140 | 4668 | 4653 | 5189 | 5282 | 5857 | 5844 | 6391 | 6482 |
| | MCD18-1/3 | 1/3 | 1725 | 3450 | 76 | 135 | 145 | 4787 | 4809 | 5477 | 5656 | 5979 | 6000 | 6674 | 6858 |
| | MCD18-1 | 1 | 1725 | 4600 | 77 | 145 | 155 | 5250 | 5099 | 6009 | 6107 | 6450 | 6296 | 7208 | 7299 |
| 24" | MCD24-1/4 | 1/4 | 1725 | 5200 | 80 | 145 | 155 | 4809 | 4787 | 5326 | 5432 | 6063 | 6040 | 6572 | 6674 |
| | MCD24-1/3 | 1/3 | 1140 | 5300 | 74 | 155 | 165 | 5385 | 5432 | 6519 | 6577 | 6630 | 6674 | 7764 | 7823 |
| | MCD24-1/2 | 1/2 | 1725 | 6000 | 80 | 150 | 160 | 5109 | 5123 | 5918 | 5837 | 6353 | 6376 | 7162 | 7081 |
| | MCD24-3/4 | 3/4 | 1140 | 6900 | 74 | 170 | 180 | 6188 | 5723 | 6858 | 6698 | 7434 | 6968 | 8100 | 7950 |
| | MCD24-1 | 1 | 1725 | 7400 | 82 | 160 | 170 | 5438 | 5287 | 6197 | 6284 | 6684 | 6533 | 7440 | 7531 |
| | MCD24-1 1/2 | 1.5 | 1725 | 8200 | 84 | 165 | 175 | 5670 | 5485 | 7814 | 6639 | 6922 | 6729 | 9059 | 7887 |
| 30" | MCD24-3 | 3 | 1725 | 10500 | 87 | 190 | 200 | ---- | 5873 | ---- | 7110 | ---- | 7118 | ---- | 8356 |
| | MCD30-1/3 | 1/3 | 1140 | 6900 | 80 | 180 | 190 | 5837 | 5880 | 6968 | 7029 | 7217 | 7261 | 8340 | 8407 |
| | MCD30-1/2 | 1/2 | 1725 | 8900 | 86 | 170 | 180 | 5565 | 5581 | 6386 | 6296 | 6948 | 6960 | 7756 | 7672 |
| | MCD30-3/4 | 3/4 | 1140 | 10400 | 80 | 240 | 250 | 6527 | 6053 | 7194 | 7035 | 7899 | 7434 | 8567 | 8417 |
| | MCD30-1 | 1 | 1140 | 11200 | 81 | 230 | 240 | 7576 | 6322 | 8798 | 7253 | 8954 | 7703 | 10170 | 8626 |
| | MCD30-1 1/2 | 1.5 | 1725 | 12000 | 92 | 230 | 240 | 6122 | 5927 | 8259 | 7081 | 7500 | 7306 | 9636 | 8460 |
| 36" | MCD30-2 | 2 | 1140 | 14000 | 84 | 255 | 265 | ---- | 6674 | ---- | 8002 | ---- | 8056 | ---- | 9381 |
| | MCD30-3 | 3 | 1725 | 16000 | 94 | 250 | 260 | ---- | 6218 | ---- | 7462 | ---- | 7589 | ---- | 8835 |
| | MCD36-1 | 1 | 1140 | 13000 | 82 | 295 | 305 | 8701 | 7440 | 9916 | 8362 | 10409 | 9150 | 11625 | 10078 |
| | MCD36-1 1/2 | 1.5 | 1725 | 14850 | 88 | 295 | 305 | 7194 | 7006 | 9340 | 8159 | 8967 | 8715 | 11046 | 9870 |
| | MCD36-2 | 2 | 1140 | 17500 | 82 | 300 | 310 | ---- | 7576 | ---- | 8910 | ---- | 9295 | ---- | 10622 |
| 36" | MCD36-3 | 3 | 1725 | 18500 | 90 | 315 | 325 | ---- | 7306 | ---- | 8545 | ---- | 9014 | ---- | 10253 |
| | MCD36-5 | 5 | 1725 | 23000 | 94 | 305 | 315 | ---- | 7394 | ---- | 8760 | ---- | 9114 | ---- | 10470 |

Exhaust Ventilation Guide

Minute air change chart for commercial and industrial applications

| Place | Typical | Range |
|--------------------|---------|-------|
| Assembly | (6) | 2-10 |
| Auditoriums | (6) | 1-20 |
| Bakeries | (2) | 1-3 |
| Banks | (6) | 3-10 |
| Bars | (4) | 2-5 |
| Barns | (15) | 10-20 |
| Boiler Rooms | (2) | 1-3 |
| Bowling Alley | (3) | 1-5 |
| Cafeteria | (4) | 3-5 |
| Churches | (6) | 2-10 |
| Classrooms | (6) | 4-8 |
| Compressor Rooms | (2) | 1-3 |
| Dance Halls | (6) | 2-10 |
| Dairies | (4) | 2-5 |
| Dormitories | (6) | 4-8 |
| Dry Cleaning Plant | (3) | 1-5 |

CFM Required for Ventilation = $\frac{\text{Building Cubic Feet}}{\text{Minutes Per Air Change}}$

| Place | Typical | Range | Place | Typical | Range |
|-------------------|---------|-------|-------------------|---------|-------|
| Engine Rooms | (3) | 1-5 | Mills | (4) | 2-5 |
| Factories | (7) | 4-10 | Packing Houses | (4) | 3-5 |
| Foundries | (5) | 2-8 | Plants | (7) | 4-10 |
| Garages | (7) | 4-10 | Plating Plants | (4) | 2-5 |
| Generating Plants | (4) | 2-5 | Print Shops | (7) | 4-10 |
| Glass Plants | (2) | 1-3 | Restaurants | (6) | 2-10 |
| Gymnasiums | (6) | 2-10 | Rest Rooms | (7) | 4-10 |
| Hallways | (8) | 4-12 | Schools | (7) | 4-10 |
| Kitchens (Comm.) | (3) | 1-5 | Stores | (7) | 4-10 |
| Laboratories | (3) | 1-5 | Theaters | (6) | 4-8 |
| Libraries | (4) | 2-5 | Transformer Rooms | (3) | 1-5 |
| Laundries | (2) | 1-3 | Turbine Rooms | (4) | 2-5 |
| Locker Rooms | (6) | 2-10 | Waiting Rooms | (12) | 10-15 |
| Machine Shops | (4) | 2-5 | Warehouses | (7) | 4-10 |
| Markets | (6) | 2-10 | Welding Rooms | (3) | 1-4 |

Note: Products listed in this section are custom built and subject to 100% cancellation/restocking charges

Industrial Workstation Floor Fans



HIGH STAND



WARNING: This product can expose you to chemicals including nickel which is known to the State of California to cause cancer, and chromium, which is known to the State of California to cause birth defects and/or reproductive harm. For more information go to www.P65Warnings.ca.gov.



FLOOR MODEL

Features

- Rotary switch
- Head tilts 360°
- Coated steel guards
- SJT type 3 conductor, 10' long cord
- Steel hub/spider aluminum paddle blades
- Meets OSHA standards
- 1 Year limited warranty
- Imported to TPI specifications.

Motor Specifications

- Sleeve bearing
- Totally enclosed
- 1-Phase, 120V
- 3-Speed
- Permanently lubricated
- Frame size: 42
- 5/16" Shaft

Standard Models

| SIZE | MFG CATALOG NUMBER | MFG MODEL NUMBER | FAN TYPE | MOTOR HP | CFM** / RPM | | | VELOCITY PROFILE CFM / Area Sq Ft | DIMENSIONS | | | MAX AMPS | WT. (LBS) | LIST |
|------|--------------------|------------------|-------------|----------|-------------|-------------|-------------|--------------------------------------|------------|---------|---------|----------|-----------|------------|
| | | | | | HIGH | MED | LOW | | "H" | "W" | "D" | | | |
| 12" | 07986102 | F-12-TE | FLOOR MODEL | 1/12 | 900 / 1590 | 800 / 1380 | 700 / 1080 | 1400 / 50 | 15 1/4" | 14 1/2" | 9 1/2" | 1.1 | 13 | 195 |
| 18" | 07972902 | F-18-TE | | 1/8 | 1800 / 1660 | 1500 / 1550 | 1300 / 1370 | 2900 / 125 | 20 1/2" | 20 1/2" | 10 1/2" | 2.2 | 20 | 245 |
| 24" | 08528502 | F-24-TE | | 1/8 | 2100 / 1634 | 1900 / 1484 | 1600 / 1200 | 3500 / 150 | 26" | 26" | 10 1/2" | 2.4 | 23 | 295 |
| 24" | 08775402 | F-24-TE-HV | | 1/4 | 3800 / 1100 | 3600 / 950 | 3400 / 800 | 6000 / 240 | 26" | 26" | 10 1/2" | 2.7 | 25 | 335 |
| 18" | 07973002 | F-18H-TE* | HIGH STAND | 1/8 | 1800 / 1660 | 1500 / 1550 | 1300 / 1370 | 2900 / 125 | 53" | 25" | 27" | 2.2 | 27 | 369 |
| 24" | 08540602 | F-24H-TE* | | 1/8 | 2100 / 1634 | 1900 / 1484 | 1600 / 1200 | 3500 / 150 | 53" | 30" | 27" | 2.4 | 30 | 413 |

**Measured 2 feet from face of fan

Corrosion Resistant Industrial Workstation Fans



HIGH STAND



WALL/CEILING MODEL



FLOOR MODEL

WARNING: This product can expose you to chemicals including nickel which is known to the State of California to cause cancer, and chromium, which is known to the State of California to cause birth defects and/or reproductive harm. For more information go to www.P65Warnings.ca.gov.

Features

- Pull chain switch
- Head tilts 360°
- FDA white coated steel guards
- SJTW type 3 conductor, 10' long cord
- Steel hub/spider aluminum paddle blades
- Corrosion resistant motor and switch
- Meets OSHA standards / 1 Year limited warranty
- Made in U.S.A. with domestic and foreign components



Motor Specifications

- Sleeve bearing
- Totally enclosed
- 1-Phase, 120V
- 3-Speed
- Permanently lubricated
- Frame size: 42
- 1/2" Shaft
- Sealed electrical enclosure

Standard Models

| SIZE | MFG CATALOG NUMBER | MFG MODEL NUMBER | FAN TYPE | MOTOR HP | CFM* / RPM | | | VELOCITY PROFILE CFM / Area Sq Ft | DIMENSIONS | | | MAX AMPS | WT. (LBS) | LIST |
|------|--------------------|------------------|--------------------|----------|-------------|-------------|-------------|--------------------------------------|------------|---------|---------|----------|-----------|------------|
| | | | | | HIGH | MED | LOW | | "H" | "W" | "D" | | | |
| 18" | 08763202 | F-18-CR | FLOOR MODEL | 1/8 | 1800 / 1660 | 1500 / 1550 | 1300 / 1370 | 2900 / 125 | 20 1/2" | 20 1/2" | 10 1/2" | 2.2 | 20 | 514 |
| 24" | 08763502 | F-24-CR | | 1/8 | 2100 / 1634 | 1900 / 1484 | 1600 / 1200 | 3500 / 150 | 26" | 26" | 10 1/2" | 2.4 | 23 | 586 |
| 18" | 08763302 | F-18H-CR | HIGH STAND | 1/8 | 1800 / 1660 | 1500 / 1550 | 1300 / 1370 | 2900 / 125 | 53" | 25" | 27" | 2.2 | 27 | 681 |
| 24" | 08763602 | F-24H-CR | | 1/8 | 2100 / 1634 | 1900 / 1484 | 1600 / 1200 | 3500 / 150 | 53" | 30" | 27" | 2.4 | 30 | 734 |
| 18" | 08763102 | U-18-CR | WALL/CEILING MODEL | 1/8 | 1800 / 1660 | 1500 / 1550 | 1300 / 1370 | 2900 / 125 | 21 1/2" | 20 1/2" | 10 1/2" | 2.2 | 20 | 514 |
| 24" | 08763402 | U-24-CR | | 1/8 | 2100 / 1634 | 1900 / 1484 | 1600 / 1200 | 3500 / 150 | 27" | 26" | 10 1/2" | 2.4 | 23 | 586 |

*Measured 2 feet from face of fan

Industrial Mounted Workstation Fans

Features



⚠️ WARNING: This product can expose you to chemicals including nickel which is known to the State of California to cause cancer, and chromium, which is known to the State of California to cause birth defects and/or reproductive harm. For more information go to www.P65Warnings.ca.gov.

- Pull chain switch
- Head rotates 360° vertically and horizontally
- Coated steel guards
- SJT type 3 conductor, 10' long cord
- Steel hub/spider aluminum paddle blades
- Meets OSHA standards / 1 Year limited warranty
- Imported to TPI specifications



| FAN SIZE | DIMENSIONS | | |
|----------|------------|-------|-------|
| | "H" | "W" | "D" |
| 12" | 15 ¼" | 14 ½" | 9 ½" |
| 18" | 21 ½" | 20 ½" | 10 ½" |
| 24" | 27" | 26" | 10 ½" |

Motor Specifications

- Sleeve bearing
- Totally enclosed, permanently lubricated
- Frame size: 42
- 3-Speed
- 1-Phase, 120V
- 5/16" (12" fan only) and ½" shaft

Standard Models

Pipe Mount Adaptor

| FAN SIZE | MFG CATALOG NUMBER | MFG MODEL NUMBER | MOTOR HP | CFM* / RPM | | | VELOCITY PROFILE | MAX AMPS | WT. (LBS) | LIST | PIPE DIAMETER | MFG CATALOG NUMBER | MFG MODEL NUMBER | LIST |
|----------|--------------------|------------------|----------|-------------|-------------|-------------|------------------|----------|-----------|------------|---------------|--------------------|------------------|-----------|
| | | | | HIGH | MED | LOW | CFM / Area Sq Ft | | | | | | | |
| 12" | 07986002 | U-12-TE | 1/12 | 900 / 1590 | 800 / 1380 | 700 / 1080 | 1400 / 50 | 1.1 | 13 | 205 | 1" | 08512402 | PM-1 | 67 |
| 18" | 07972802 | U-18-TE | 1/8 | 1800 / 1660 | 1500 / 1550 | 1300 / 1370 | 2900 / 125 | 2.2 | 20 | 253 | 1 ½" | 08512502 | PM-1.5 | 74 |
| 24" | 08540702 | U-24-TE | 1/8 | 2100 / 1634 | 1900 / 1484 | 1600 / 1200 | 3500 / 150 | 2.4 | 23 | 284 | 2" | 08512602 | PM-2 | 82 |
| 24" | 08775502 | U-24-TE-HV | 1/4 | 3800 / 1100 | 3600 / 950 | 3400 / 800 | 6000 / 240 | 2.7 | 25 | 302 | 2 ½" | 08512702 | PM-2.5 | 88 |
| | | | | | | | | | | | 3" | 08512802 | PM-3 | 96 |

*Measured 2 feet from face of fan

Note: Mount with one bolt or lag screw to walls, ceilings, work benches, machines or any surface.

Outdoor Rated Yoke Mount Fans

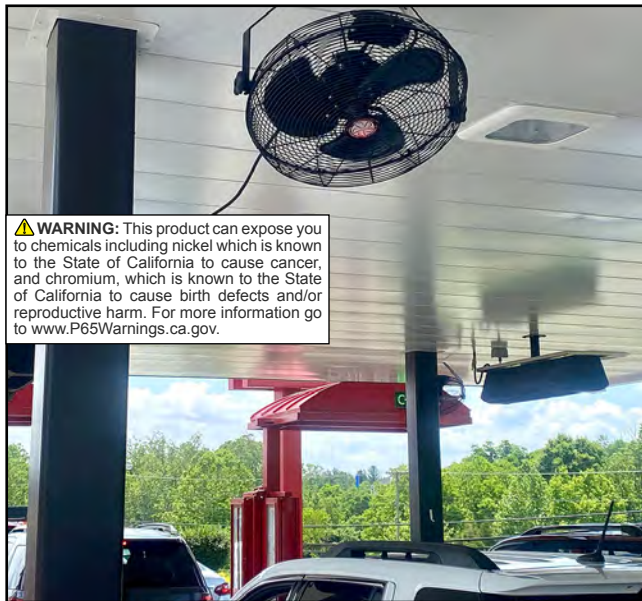

⚠️ WARNING: This product can expose you to chemicals including nickel which is known to the State of California to cause cancer, and chromium, which is known to the State of California to cause birth defects and/or reproductive harm. For more information go to www.P65Warnings.ca.gov.

Features

- Direct drive totally enclosed motor
- Pull chain switch
- Head rotates 360° vertically and horizontally
- Knobs allow for 180° vertical rotation
- Coated black finish steel guards
- Steel yoke mounting bracket
- All black finish with aiming handle
- SJT type 3 conductor, 10' long cord
- Steel hub/spider aluminum 3-paddle blades
- Meets OSHA standards / 1 Year limited warranty
- Imported to TPI specifications



Motor Specifications

- Sleeve bearing
- Totally enclosed, permanently lubricated
- Frame size: 42
- 3-Speed
- 1-Phase, 120V
- ½" shaft



Standard Models

| FAN SIZE | MFG CATALOG NUMBER | MFG MODEL NUMBER | MOTOR HP | RPM | CFM | | | VELOCITY PROFILE | MAX AMPS | WT. (LBS) | LIST |
|----------|--------------------|------------------|----------|------|------|------|------|------------------|----------|-----------|------------|
| | | | | | HIGH | MED | LOW | CFM/Area Sq. Ft. | | | |
| 18" | 08194502 | U-18-TE-HD | 1/10 | 1625 | 1900 | 1500 | 1300 | 3100 / 125 | 1.1 | 20 | 292 |
| 24" | 08211802 | U-24-TE-HD | 1/4 | 1625 | 3800 | 3600 | 3400 | 6000 / 240 | 2.4 | 28 | 313 |

*Measured 2 feet from face of fan

TPI Commercial Floor Fans

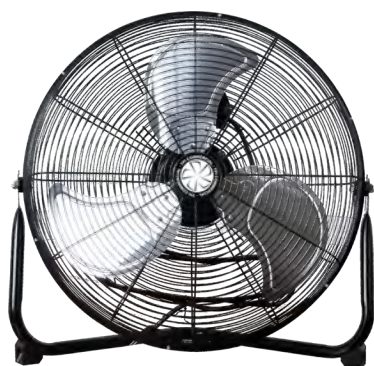

CF-20



WARNING: This product can expose you to chemicals including nickel which is known to the State of California to cause cancer, and chromium, which is known to the State of California to cause birth defects and/or reproductive harm. For more information go to www.P65Warnings.ca.gov.

Features

- Rotary switch
- SJT type cord - 3 conductor - 7' long
- Aluminum blade
- Coated steel guards with retaining clips
- Meets OSHA standards / 1 Year limited warranty
- Imported to TPI specifications

Motor Specification

- 3-Speed
- 120V
- Sleeve bearing
- 1-Phase
- Open ventilated
- Permanently lubricated

Standard Models

| MFG CATALOG NUMBER | MFG MODEL NUMBER | SIZE | TYPE | MOTOR HP | CFM | | | MAX AMPS | WT. (LBS) | LIST |
|--------------------|------------------|------|-------|----------|------|------|------|----------|-----------|------------|
| | | | | | HIGH | MED | LOW | | | |
| 08723002 | CF-12 | 12" | FLOOR | 1/12 | 1050 | 875 | 750 | 0.6 | 10 | 114 |
| 08723102 | CF-18 | 18" | FLOOR | 1/5 | 1600 | 1480 | 1380 | 1.4 | 16 | 141 |
| 08706502 | CF-20 | 20" | FLOOR | 1/5 | 1725 | 1600 | 1480 | 1.9 | 18 | 195 |

Units should be used in clean, dry, commercial applications. **Note: Photograph is a representation of stocked models. Actual model may vary in appearance.**

Workstation Oscillating Office Fans



STAND FAN



DESK FAN



Features

- 3-speed oscillating fans with push button controls
- 3 conductor SPT cord & plug
- White powder coated wire mesh guards
- White plastic housing and blade
- Stand fan extends to 40" height
- Meets OSHA standards / 1 Year limited warranty
- Imported to TPI specifications

WARNING: This product can expose you to chemicals including nickel which is known to the State of California to cause cancer, and chromium, which is known to the State of California to cause birth defects and/or reproductive harm. For more information go to www.P65Warnings.ca.gov.

Standard Models

| SIZE | MFG CATALOG NUMBER | MFG MODEL NUMBER | FAN TYPE | SPEEDS | CFM HIGH | AMPS HIGH | WT. (LBS) | LIST |
|------|--------------------|------------------|----------|--------|----------|-----------|-----------|------------|
| 12" | 08513002 | ODF-12 | DESK | 3 | 860 | 0.4 | 5.4 | 97 |
| 16" | 08513102 | ODF-16 | DESK | 3 | 1530 | 0.5 | 8.5 | 114 |
| 16" | 08513202 | OSF-16 | STAND | 3 | 1530 | 0.5 | 15.5 | 144 |

Workstation Wall Mount Fan With Pivoting Arm

18" HIGH VELOCITY FAN MOUNTED ON 24", 40", or 60" PIVOTING ARMS



WARNING: This product can expose you to chemicals including nickel which is known to the State of California to cause cancer, and chromium, which is known to the State of California to cause birth defects and/or reproductive harm. For more information go to www.P65Warnings.ca.gov.

Mounting Arm Features

- 1 1/2" square, 14 gauge, steel tubing
- 3" x 5" x 3/16" mounting plate attaches with (4) 3/8" bolts
- 5' long, 18/5 SJTW conductor cord and NEMA 5-15 grounded plug
- Dual electrical outlets embedded in arm to allow connection of modular fan and optional light
- Made in U.S.A. with domestic and foreign components



Modular Fan Features

- 18" high velocity circulator, with 3 speed, 1/8 HP, 115V, 1-Phase permanently lubricated, totally enclosed, PSC motor
- Modular fan plugs into electrical outlet on arm
- Coated steel guards / Aluminum blades
- Meets OSHA standards / 1 year limited warranty

Use on loading docks to cool off workers entering hot truck trailers.

Use at factory workstations to cool off people or the machines.

Standard Models

| MFG CATALOG NUMBER | MFG MODEL NUMBER | FAN SIZE | ARM LENGTH | FAN CFM* | | | VELOCITY PROFILE CFM / Area Sq Ft | MAX AMPS | WT. (LBS) | LIST |
|--------------------|------------------|----------|------------|----------|------|------|--------------------------------------|----------|-----------|------|
| | | | | HIGH | MED | LOW | | | | |
| 08009102 | 24-LDF-TE | 18" | 24" | 1800 | 1500 | 1300 | 2900 / 125 | 2.2 | 31 | 401 |
| 08009202 | 40-LDF-TE | | 40" | | | | | | | |
| 08009302 | 60-LDF-TE | | 60" | | | | | | | |

*Measured 2 feet from face of fan

Loading Dock Arm Fan

| MFG CATALOG NUMBER | MFG MODEL NUMBER | FAN SIZE | FAN CFM* | | | MAX AMPS | WT. (LBS) | LIST |
|--------------------|------------------|----------|----------|------|------|----------|-----------|------|
| | | | HIGH | MED | LOW | | | |
| 07971802 | LDF-18-TE | 18" | 1800 | 1500 | 1300 | 2.2 | 20 | 257 |

Optional Modular Lights



DKL-INC



DKL-QH



Light Features

- Plugs into embedded outlet in arm
- On/Off switch and wire guard included
- Bulb included with DKL-QH and DKL-FL
- Made in U.S.A. with domestic and foreign components

Standard Models

WARNING: This product can expose you to chemicals including nickel which is known to the State of California to cause cancer, and chromium, which is known to the State of California to cause birth defects and/or reproductive harm. For more information go to www.P65Warnings.ca.gov.

| MFG CATALOG NUMBER | MFG MODEL NUMBER | LIGHT HEAD TYPE | MAX WATTS | MAX LUMENS | AVE. BULB LIFE (HRS) | WT. (LBS) | LIST |
|--------------------|------------------|-----------------|-----------|------------|----------------------|-----------|------|
| 04465602 | DKL-INC | Incandescent | 300 | 3,700 | 2,000 | 5 | 106 |
| 04465702 | DKL-QH | Quartz Halogen | 500 | 11,000 | 2,000 | 6 | 159 |

Low Velocity "Special Application" Workstation Fan

Features



WALL MOUNT

WARNING: This product can expose you to chemicals including nickel which is known to the State of California to cause cancer, and chromium, which is known to the State of California to cause birth defects and/or reproductive harm. For more information go to www.P65Warnings.ca.gov.

- 12" aluminum blade air circulator for wall, ceiling, or bench mount
- 120V, 1-phase, 1/12HP with direct wire electrical connection
- Toggle switch with 2-speed control generating up to 1200 CFM
- All metal construction with a gray powder coated finish
- Fan head tilts 90° in horizontal and vertical plane
- Conforms to U.S. Navy Specification MIL-DTL-68G
- Meets OSHA standards / 1-year limited warranty
- Made in the U.S.A. with domestic and foreign components

Standard Models



BENCH MOUNT



CEILING MOUNT

| SIZE | MFG CATALOG NUMBER | MFG MODEL NUMBER | MOTOR HP | CFM* / RPM | | VELOCITY PROFILE CFM / Area Sq Ft | AMPS HIGH | WT. (LBS) | LIST |
|------|--------------------|------------------|----------|------------|------------|--------------------------------------|-----------|-----------|------|
| | | | | HIGH | LOW | | | | |
| 12" | 08708902 | N-12 | 1/12 | 800 / 1350 | 600 / 1000 | 1200 / 40 | 0.6 | 12 | 418 |

*Measured 2 feet from face of fan

Portable 18" Self Contained Power Mister

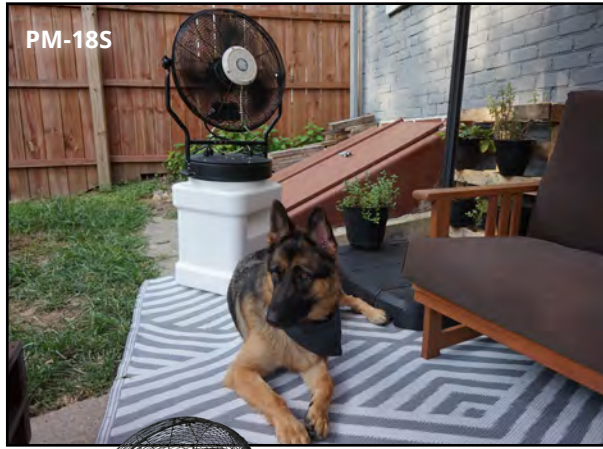

This outdoor rated portable misting system operates at 120-Volts and is created through the process of evaporation. TPI's self-contained power misting equipment creates a "fog" by pumping water at a medium flow rate through small nozzles from the misting hub. When combined with the air added by fan blades, this fog is rapidly evaporated. The heat required to evaporate the fog is extracted from the air causing a reduced air temperature. This cooler air is then distributed to people or animals creating a direct cooling zone.

Features

- Medium pressure 125 PSI diaphragm pumps water from a 10-gallon tank providing a "fog" like misting zone that can cover up to 400-sg.ft.
- 3-speed non-oscillating 18" diameter 3-paddle blades operates at 120-Volt, generates over 3100-CFMs pulling less than 3-amps, and includes an 18' long GFCI cord and 3-prong cord.
- Totally enclosed, weather-tight, 1/10-HP motor is UL / C-UL recognized, designed for outdoor applications, and is encased with steel spiral front and rear wire guards that meets OSHA requirements
- 4-nozzle misting hub system is standard, and additional misting nozzle and safety caps included
- Cart and stand models include a 10-gallon white water container including fill-line, drain cap & intake line with filter
- PM18-C model contains a black finish steel frame, includes operating handle, tank platform, upright stem and 10" wheel base and is shipped unassembled
- PM18-F offered a replacement fan head unit is shipped with no water container and can be placed onto existing 10-gallon igloo coolers
- Shipped in one single carton; unit is designed, engineered, tested and assembled in the U.S.A.



Additional nozzle & caps included with all models



Units include intake tubing line and water filter



Switch allows for Off, Fan Only or Fan & Mist Operation



PM-18FO

Motor Specification

- 1-Phase / 120V
- 3-Speed, 1/10 HP
- Sleeve bearing
- Permanently lubricated
- Totally Enclosed
- Weather-tight
- Outdoor rated
- All (3) models contain the same fan head, misting ring and pump assembly

Standard Models

| MFG CATALOG NUMBER | MFG MODEL NUMBER | TYPE | FAN SIZE | MOTOR HP | AMPS | CFM* | VELOCITY PROFILE | WT. (LBS) | LIST |
|--------------------|------------------|---------------|----------|----------|------|------|------------------|-----------|-------------|
| | | | | | | | CFM / Area Sq Ft | | |
| 08554702 | PM-18S | Hand Carry | 18" | 1/10 | 1.1 | 1900 | 3100 / 140 | 30 | 1431 |
| 08554902 | PM-18C | Cart | | | | | | 76 | 1820 |
| 08555202 | PM-18FO | Fan Head Only | | | | | | 28 | 1226 |

*Measured 2 feet from face of fan

Replacement Parts

| MFG CATALOG NUMBER | MFG MODEL NUMBER | DESCRIPTION | FITS MODELS | WT. (LBS) | LIST |
|--------------------|------------------|------------------------|-------------|-----------|-----------|
| 08760702 | NK-PM18 | REPLACEMENT NOZZLE KIT | All PM18s | 1 | 34 |

⚠ WARNING: This product can expose you to chemicals including nickel which is known to the State of California to cause cancer, and chromium, which is known to the State of California to cause birth defects and/or reproductive harm. For more information go to www.P65Warnings.ca.gov.

Features

- 120-Volt / single phase, 60HZ electrical service
- Permanently sealed double radial ball bearing PSC AC motor provides maintenance free and quiet operation
- Low energy consumption – high efficiency performance
- White powder coated finish on steel motor housing & downrod
- White polymer 3-paddle blade system designed for quiet operation
- Includes 24" stainless steel safety cable kit
- Easy to mount to the supplied steel J-Hook connection
- Satisfies the U.S. Department of Energy's "Energy Guide" requirements
- E-CF models contain (4) 24" long lead wires for forward/reverse direct wire options providing year round operation in downflow or upflow direction
- E60-CFC has 3-speeds, includes cord/controller & IP65 rated equivalent for wet locations
- ETL Listed for USA & Canada / 5-year limited warranty



Models: E56-CF or E60-CF

Forward / Reverse wiring options



Model: E60-CFC

Indoor / Outdoor Rated
Plug & Play Install
Includes Speed Controller



Motor Specifications

- 1-Phase, 120V
- Permanently sealed
- Ball bearing PSC AC Motor

| Model # | Amps | Watts |
|---------|------|-------|
| E-56CF | 0.70 | 85 |
| E-60CF | 0.70 | 90 |
| E-60CFC | 0.80 | 95 |

WARNING: This product can expose you to chemicals including nickel which is known to the State of California to cause cancer, and chromium, which is known to the State of California to cause birth defects and/or reproductive harm. For more information go to www.P65Warnings.ca.gov.



Standard Models

| MFG CATALOG NUMBER | MFG MODEL NUMBER | BLADE DIAMETER | AIRFLOW OPTIONS | DOWNROD LENGTH | MAX CFM | MOTOR RPM | MOTOR TYPE | CORD INCLUDED | SPEED CONTROLLER | WEIGHT (LBS.) | LIST |
|--------------------|------------------|----------------|-----------------|----------------|---------|-----------|----------------|---------------|-------------------|---------------|------|
| 08198202 | E-56CF | 56" | Forward/Reverse | 18" | 7,775 | 290 | Moisture Rated | None | Sold Separately | 22 | 276 |
| 08198302 | E-60CF | 60" | Forward/Reverse | 18" | 8,434 | 260 | Moisture Rated | None | Sold Separately | 22 | 340 |
| 08198402 | E-60CFC | 60" | Down Draft | 24" | 9,630 | 250 | Wet Rated | Yes | Included; 3-Speed | 28 | 535 |

Accessories

| MFG CATALOG NUMBER | MFG MODEL NUMBER | TYPE | VOLTS | MAX AMPS | VARIABLE CONTROL KNOB | REVERSING SWITCH | # OF FANS | FOR USE WITH | LIST |
|--------------------|------------------|--|--|----------|----------------------------------|------------------|-----------|----------------|------|
| 07994102 | KBWC-110K | Solid State Variable Speed Controllers | 120 | 10 | Yes w/ 3" X 5" Aluminum Plate ** | No | 1-10 | All 3-Models | 218 |
| 08666802 | KBWC-15SK | | | 5 | | Yes | 1-5 | E-56CF & E60CF | 200 |
| 08210602 | DR36 | Down Rod Extender | 36" long, steel, white finish, 3/4" diameter | | | | | All 3-Models | 63 |

** Fits 2" x 4" Opening

How to Determine the Total # of Ceiling Fans Needed

| Ceiling Height (feet) | Coverage Area (square feet) |
|-----------------------|-----------------------------|
| 10 - 11 | 600 |
| 12 - 13 | 800 |
| 14 - 15 | 950 |
| 16 - 17 | 1100 |
| 18 - 19 | 1300 |
| 20 - 21 | 1450 |

What to Measure:
Total Square Footage (L x W)
Maximum Ceiling Height

Small Area Example:

If you had a 3,000 square foot facility with 16' ceilings:
Calculation (Total Sq.Ft. / Coverage Area): 3,000/1,100 = 2.73
Total # of fans needed = 3

Large Area Example:

If you had a 10,000 square foot facility with 13' ceilings:
Calculation (Total Sq.Ft. / Coverage Area): 10,000/800 = 12.5
Total # of fans needed = 12 (See chart for layout)

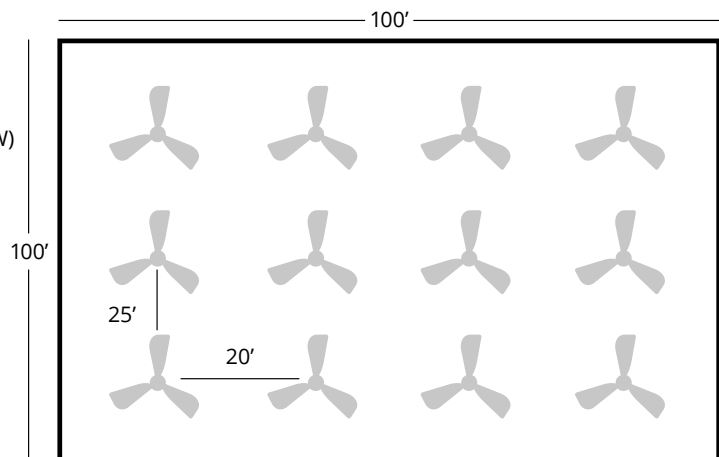

Shutter Mounted Direct Drive Exhaust Fans

Features

- Can be installed from inside wall
- Eliminates need for external framing and shutter
- Pull chain switch
- No Cord-Junction box provided for direct wiring
- Aluminum blade
- Steel spiral wire guards
- Made in U.S.A. with domestic and foreign components.
- See sizing chart on page 17



Motor Specifications

- 120V, 1-Phase, totally enclosed, permanently lubricated
- 1/12 HP motor is 3-Speed sleeve bearing permanent split capacitor
- 1/8 HP motor is 3-Speed sleeve bearing permanent split capacitor
- 1/4 HP motor is 2-Speed ball bearing permanent split capacitor

⚠ WARNING: This product can expose you to chemicals including nickel which is known to the State of California to cause cancer, and chromium, which is known to the State of California to cause birth defects and/or reproductive harm. For more information go to www.P65Warnings.ca.gov.

Note: Rough-in hole size is 1/2" inch larger than fan blade size

Standard Models

| FAN SIZE | MFG CATALOG NUMBER | MFG MODEL NUMBER | HP | CFM / RPM | | | AMPS HIGH | WT. (LBS) | LIST |
|----------|--------------------|------------------|------|-------------|-------------|-------------|-----------|-----------|-------------|
| | | | | HIGH | MED | LOW | | | |
| 10" | 08689902 | CE 10-DS | 1/12 | 680 / 1560 | 540 / 1250 | 460 / 1080 | 1 | 11 | 402 |
| 12" | 07986202 | CE 12-DS | 1/12 | 825 / 1560 | 710 / 1250 | 560 / 1080 | 1.1 | 16 | 456 |
| 14" | 08690002 | CE 14-DS | 1/8 | 1520 / 1660 | 1400 / 1550 | 1250 / 1370 | 2 | 17 | 576 |
| 16" | 08690102 | CE 16-DS | 1/8 | 2100 / 1660 | 1900 / 1550 | 1700 / 1370 | 2.1 | 18 | 603 |
| 18" | 07986302 | CE 18-DS | 1/8 | 2300 / 1660 | 2100 / 1050 | 1850 / 1370 | 2.2 | 25 | 655 |
| 20" | 08690202 | CE 20-DS | 1/4 | 2925 / 1140 | - | 2380 / 1070 | 2.3 | 34 | 777 |
| 24" | 07986402 | CE 24-DS | 1/4 | 3400 / 1140 | - | 2770 / 1070 | 2.5 | 47 | 863 |
| 30" | 07986502 | CE 30-DS | 1/4 | 3950 / 1140 | - | 3080 / 1070 | 2.7 | 54 | 1082 |

Dimensions (Inches)

| SIZE | DEPTH | DIMENSIONS | | |
|------|-------|------------|-----|---------|
| | | "A" | "B" | "C" |
| 10" | 5.81" | 13.125" | 10" | 12.375" |
| 12" | 7.18" | 15.125" | 12" | 14.375" |
| 14" | 7.18" | 17.125" | 14" | 16.375" |
| 16" | 7.18" | 19.125" | 16" | 18.250" |
| 18" | 7.18" | 21.125" | 18" | 21.750" |
| 20" | 7.18" | 23.125" | 20" | 23.686" |
| 24" | 7.18" | 27.125" | 24" | 27.750" |
| 30" | 7.18" | 33.125" | 30" | 33.750" |

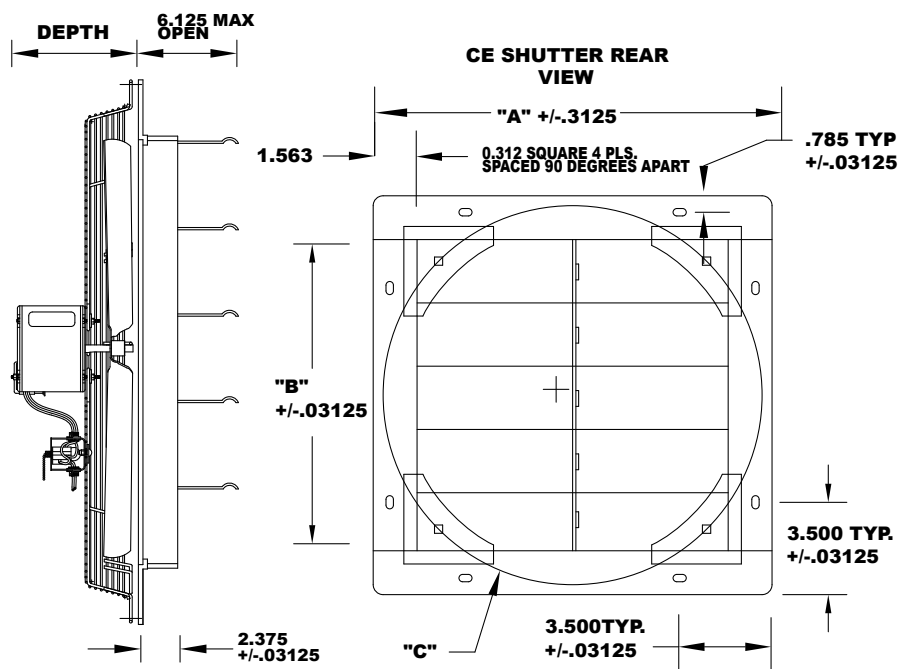

Guard Mounted Direct Drive Exhaust Fans

Features

- Bolts directly to the wall
- Can be used with or without external shutter
- Pull chain switch
- No Cord-Junction box provided for direct wiring
- Aluminum blade
- Steel spiral wire guards
- Made in U.S.A. with domestic and foreign components.

WARNING: This product can expose you to chemicals including nickel which is known to the State of California to cause cancer, and chromium, which is known to the State of California to cause birth defects and/or reproductive harm. For more information go to www.P65Warnings.ca.gov.

Note: Rough-in hole size is 1/2" inch larger than fan blade size

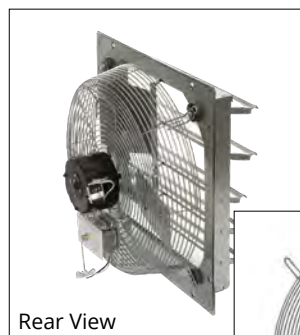

Rear View

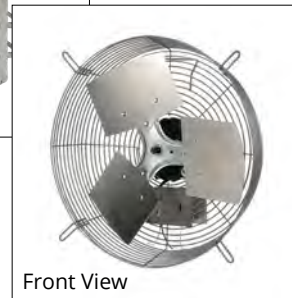

Front View

Motor Specifications

- 120V, 1-Phase, totally enclosed, permanently lubricated
- 1/12 HP motor is 3-Speed sleeve bearing permanent split capacitor
- 1/8 HP motor is 3-Speed sleeve bearing permanent split capacitor
- 1/4 HP motor is 2-Speed ball bearing permanent split capacitor

Standard Models

| FAN SIZE | MFG CATALOG NUMBER | MFG MODEL NUMBER | HP | CFM / RPM | | | AMPS HIGH | WT. (LBS) | LIST |
|----------|--------------------|------------------|------|-------------|-------------|-------------|-----------|-----------|------------|
| | | | | HIGH | MED | LOW | | | |
| 10" | 08689502 | CE 10-D | 1/12 | 680 / 1560 | 540 / 1250 | 460 / 1080 | 1 | 11 | 342 |
| 12" | 07985002 | CE 12-D | 1/12 | 825 / 1560 | 710 / 1250 | 560 / 1080 | 1.1 | 12 | 386 |
| 14" | 08689602 | CE 14-D | 1/8 | 1520 / 1660 | 1400 / 1550 | 1250 / 1370 | 2 | 17 | 410 |
| 16" | 08689702 | CE 16-D | 1/8 | 2100 / 1660 | 1900 / 1550 | 1700 / 1370 | 2.1 | 18 | 428 |
| 18" | 07984902 | CE 18-D | 1/8 | 2300 / 1660 | 2100 / 1050 | 1850 / 1370 | 2.2 | 19 | 470 |
| 20" | 08689802 | CE 20-D | 1/4 | 2925 / 1140 | - | 2380 / 1070 | 2.3 | 34 | 611 |
| 24" | 07984802 | CE 24-D | 1/4 | 3400 / 1140 | - | 2770 / 1070 | 2.5 | 38 | 680 |
| 30" | 07984702 | CE 30-D | 1/4 | 3950 / 1140 | - | 3080 / 1070 | 2.7 | 42 | 793 |

Dimensions (Inches)

| SIZE | BOLT HOLE CENTER WIDTH | DEPTH |
|------|------------------------|-------|
| 10" | 14.14" | 5.81" |
| 12" | 16.46" | 7.18" |
| 14" | 18.30" | 7.18" |
| 16" | 20.34" | 7.18" |
| 18" | 22.64" | 7.18" |
| 20" | 25.46" | 7.18" |
| 24" | 29.08" | 7.18" |
| 30" | 34.89" | 7.18" |

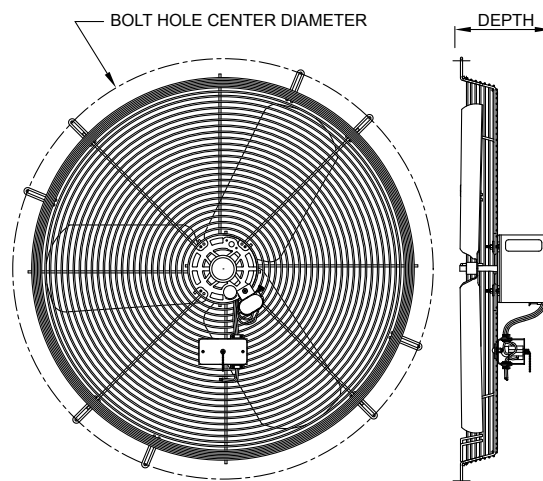

Optional Wall Shutters

| FAN SIZE | MFG CATALOG NUMBER | MFG MODEL NUMBER | WT. (LBS) | LIST |
|----------|--------------------|------------------|-----------|------------|
| 10" | 08684302 | CES-10G | 5 | 91 |
| 12" | 07985502 | CES-12G | 5.5 | 126 |
| 14" | 08684502 | CES-14G | 6.5 | 154 |
| 16" | 08514702 | CES-16G | 8 | 179 |
| 18" | 07985602 | CES-18G | 9 | 216 |
| 20" | 07975202 | CES-20G | 10 | 240 |
| 24" | 07985702 | CES-24G | 13 | 268 |
| 30" | 07985802 | CES-30G | 19 | 313 |

Venturi Mounted Direct Drive Exhaust Fans

Features

- Can be installed from inside wall
- Can be used with external shutter
- Pull chain switch
- No Cord-Junction box provided for direct wiring
- Aluminum blade
- Steel spiral wire guards
- Made in U.S.A. with domestic and foreign components



Motor Specifications

- 120V, 1-Phase, totally enclosed, permanently lubricated
- 1/12 HP motor is 3-Speed sleeve bearing permanent split capacitor
- 1/8 HP motor is 3-Speed sleeve bearing permanent split capacitor
- 1/4 HP motor is 2-Speed ball bearing permanent split capacitor

WARNING: This product can expose you to chemicals including nickel which is known to the State of California to cause cancer, and chromium, which is known to the State of California to cause birth defects and/or reproductive harm. For more information go to www.P65Warnings.ca.gov.

Note: Rough-in hole size is 1/2" inch larger than fan blade size

Standard Models

| FAN SIZE | MFG CATALOG NUMBER | MFG MODEL NUMBER | HP | CFM / RPM | | | AMPS HIGH | WT. (LBS) | LIST |
|----------|--------------------|------------------|------|-------------|-------------|-------------|-----------|-----------|-------------|
| | | | | HIGH | MED | LOW | | | |
| 10" | 08690302 | CE 10-DV | 1/12 | 680 / 1560 | 540 / 1250 | 460 / 1080 | 1 | 11 | 402 |
| 12" | 07986602 | CE 12-DV | 1/12 | 825 / 1560 | 710 / 1250 | 560 / 1080 | 1.1 | 17 | 455 |
| 14" | 08690402 | CE 14-DV | 1/8 | 1520 / 1660 | 1400 / 1550 | 1250 / 1370 | 2 | 17 | 576 |
| 16" | 08690502 | CE 16-DV | 1/8 | 2100 / 1660 | 1900 / 1550 | 1700 / 1370 | 2.1 | 18 | 603 |
| 18" | 07986702 | CE 18-DV | 1/8 | 2300 / 1660 | 2100 / 1050 | 1850 / 1370 | 2.2 | 26 | 655 |
| 20" | 08690602 | CE 20-DV | 1/4 | 2925 / 1140 | - | 2380 / 1070 | 2.3 | 34 | 777 |
| 24" | 07986802 | CE 24-DV | 1/4 | 3400 / 1140 | - | 2770 / 1070 | 2.5 | 48 | 863 |
| 30" | 07986902 | CE 30-DV | 1/4 | 3950 / 1140 | - | 3080 / 1070 | 2.7 | 55 | 1082 |

Dimensions (Inches)

| SIZE | DEPTH | DIMENSIONS | | | | |
|------|-------|------------|--------|---------|--------|---------|
| | | "A" | "B" | "C" | "D" | "E" |
| 10" | 5.81" | 10.250" | 12.63" | 12.375" | 2.000" | 12.875" |
| 12" | 7.18" | 12.250" | 14.50" | 14.375" | 2.000" | 14.625" |
| 14" | 7.18" | 14.250" | 17.13" | 16.375" | 2.500" | 17.375" |
| 16" | 7.18" | 16.250" | 19.13" | 18.250" | 2.875" | 20.000" |
| 18" | 7.18" | 18.125" | 21.00" | 21.750" | 2.750" | 22.875" |
| 20" | 7.18" | 20.250" | 23.13" | 23.686" | 2.750" | 25.625" |
| 24" | 7.18" | 24.250" | 29.50" | 27.750" | 2.875" | 27.875" |
| 30" | 7.18" | 30.250" | 33.50" | 33.750" | 2.875" | 33.875" |

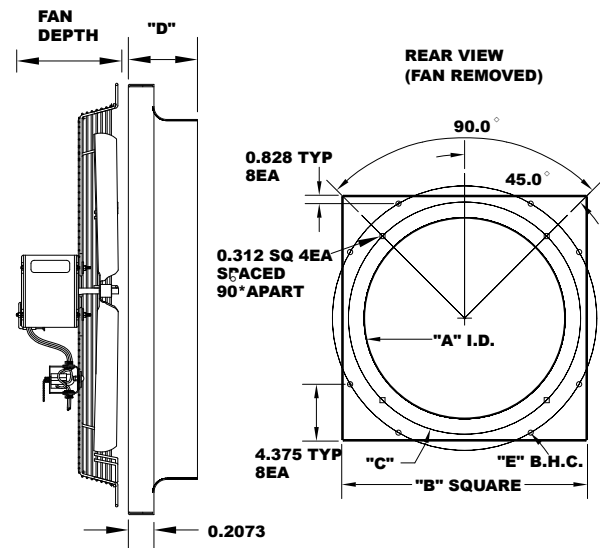

Optional Wall Shutters

| FAN SIZE | MFG CATALOG NUMBER | MFG MODEL NUMBER | DIMENSIONS | | WT. (LBS) | LIST |
|----------|--------------------|------------------|------------|--------|-----------|------------|
| | | | WIDTH | LENGTH | | |
| 10" | 08684302 | CES-10G | 13.13" | 13.13" | 5.0 | 91 |
| 12" | 07985502 | CES-12G | 15.13" | 15.13" | 5.5 | 126 |
| 14" | 08684502 | CES-14G | 17.13" | 17.13" | 6.5 | 154 |
| 16" | 08514702 | CES-16G | 19.00" | 19.00" | 8.0 | 179 |
| 18" | 07985602 | CES-18G | 21.13" | 21.13" | 9.0 | 216 |
| 20" | 07975202 | CES-20G | 23.13" | 23.13" | 10.0 | 240 |
| 24" | 07985702 | CES-24G | 27.13" | 27.13" | 13.0 | 268 |
| 30" | 07985802 | CES-30G | 33.13" | 33.13" | 19.0 | 313 |

Belt Drive Exhaust Fans & Optional Shutters

Venturi Mounted Belt Drive Exhaust Fan

Features

- Steel venturi frame exhaust fan, bolts directly to an inside wall or framed / vertical surface
- Motor is designed for direct wiring connection; NO cord provided
- Operates at 115/120V at single-phase or 230/460V at 3-phase; 1725 RPMs
- Single speed, belt drive motor constructed of ball bearing, split capacitor, drip proof and is permanently lubricated
- Steel frame has a gray powder coated finish and uses a 4-paddle aluminum blade
- Designed for harsh industrial and commercial environments to improve air quality
- Belt drive motor allows for quieter operation and higher air volume performance
- Can be used with or without external shutter (sold separately)
- UL recognized motor has a frame size of 56
- Proudly Designed, Engineered, Tested and Assembled in the USA



Dimensions (Inches)

| MODEL | DIMENSIONS A x B x C x D |
|--------|--------------------------|
| CE-24B | 29.5" x 31" x .75" x 17" |
| CE-30B | 35.5" x 34" x .75" x 17" |
| CE-36B | 41.5" x 40" x .75" x 17" |
| CE-42B | 48" x 48" x .75" x 17" |
| CE-48B | 54" x 54" x .75" x 17" |

WARNING: This product can expose you to chemicals including nickel which is known to the State of California to cause cancer, and chromium, which is known to the State of California to cause birth defects and/or reproductive harm. For more information go to www.P65Warnings.ca.gov.

Standard Models

| SIZE | MOTOR HP | AMPS | | CFM | WT. (LBS) | 115V 1-PHASE | | | 230/460V 3-PHASE | | |
|------|----------|------|-----------|--------|-----------|--------------------|------------------|-------------|--------------------|------------------|-------------|
| | | 115V | 230/460V | | | MFG CATALOG NUMBER | MFG MODEL NUMBER | LIST | MFG CATALOG NUMBER | MFG MODEL NUMBER | LIST |
| 24 | 1/3 | 5 | 1.9 / .9 | 10,000 | 50 | 07967002 | CE-24B | 978 | 08510402 | CE-24B-3 | 1125 |
| 30 | 1/3 | 6 | 1.9 / .9 | 11,600 | 60 | 07967102 | CE-30B | 1101 | 08510502 | CE-30B-3 | 1256 |
| 36 | 1/2 | 8 | 2.3 / 1.1 | 14,000 | 65 | 07967202 | CE-36B | 1272 | 08510602 | CE-36B-3 | 1421 |
| 42 | 3/4 | 11 | 3.3 / 1.5 | 17,500 | 75 | 07967302 | CE-42B | 1596 | 08510702 | CE-42-B-3 | 1980 |
| 48 | 1 | 15 | 3.8 / 1.9 | 23,500 | 98 | 07967402 | CE-48B | 1994 | 08510802 | CE-48-B-3 | 2109 |

Optional Exhaust Shutters



Features

- Air open - gravity close
- Aluminum frame
- Aluminum louvers
- Weather stripping for tighter seal
- For ONLY CE-Series BELT Drive Fans
- Made in U.S.A.

Standard Models

| MFG CATALOG NUMBER | MFG MODEL NUMBER | WT. (LBS) | LIST |
|--------------------|------------------|-----------|-------------|
| 07967502 | CES-24 | 11 | 329 |
| 07967602 | CES-30 | 15 | 402 |
| 07967702 | CES-36 | 19 | 704 |
| 07967802 | CES-42 | 23 | 896 |
| 07967902 | CES-48 | 28 | 1032 |

Shutter Dimensions (Inches)

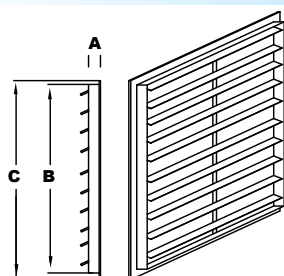

- (A) Thickness
- (B) Blade Housing Size
- (C) Overall Size

| MFG MODEL NUMBER | OUTSIDE FRAME DIMENSIONS A x C x C | INSIDE FRAME DIMENSIONS B x B |
|------------------|------------------------------------|-------------------------------|
| CES-24 | 3" x 27" x 27" | 24" x 24" |
| CES-30 | 3" x 33" x 33" | 30" x 30" |
| CES-36 | 3" x 39" x 39" | 36" x 36" |
| CES-42 | 3" x 45" x 45" | 42" x 42" |
| CES-48 | 3" x 51" x 51" | 48" x 48" |

* Recommend adding 1/2" to inside frame dimension for wall opening

Industrial Direct Drive Exhaust Fans

Features

- Totally enclosed motors:
 - 1-Phase motors are field convertible 115V / 230V
 - 3-Phase motors are field convertible 230V / 460V
 - Motors are set to lower voltage at the factory, unless a request is made at time of order to set to the higher voltage
- 14 gauge steel venturi with steel pipe bracing
- 4-blade steel propeller
- 1 year limited warranty



Options

- CES Shutters
- EMF Front Guards
- IBG Rear Guards

⚠ WARNING: This product can expose you to chemicals including nickel which is known to the State of California to cause cancer, and chromium, which is known to the State of California to cause birth defects and/or reproductive harm. For more information go to www.P65Warnings.ca.gov.

Standard Models

| BLADE SIZE | MFG MODEL NUMBER | | PANEL SIZE (Sq.) | HP | RPM | CFM 0° SP | db's @ 10' | WT. (LBS) | LIST | |
|------------|------------------|-------------------|------------------|-----|------|-----------|------------|-----------|------|------|
| | 1-PHASE | 3-PHASE | | | | | | | TEC | |
| | 115/230V-60Hz | 208/230/460v-60Hz | | | | | | | 1 PH | 3 PH |
| 12" | IED12-1/4 | IED12-1/4-3 | 16" | 1/4 | 1725 | 1480 | 64 | 30 | 1671 | 1676 |
| 16" | IED16-1/3 | IED16-1/3-3 | 20" | 1/3 | 1725 | 2834 | 73 | 40 | 2000 | 2041 |
| 18" | IED18-1/2 | IED18-1/2-3 | 24" | 1/2 | 1725 | 3890 | 74 | 55 | 2247 | 2266 |
| 20" | IED20-3/4 | IED20-3/4-3 | 24" | 3/4 | 1725 | 4574 | 77 | 65 | 2610 | 2610 |
| 24" | IED24-1 | IED24-1-3 | 30" | 1 | 1725 | 6632 | 81 | 155 | 3012 | 2849 |
| 30" | IED30-1 | IED30-1-3 | 36" | 1 | 1150 | 8600 | 79 | 185 | 5897 | 3414 |
| 36" | IED36-1 1/2 | IED36-1 1/2-3 | 42" | 1.5 | 1150 | 12103 | 82 | 260 | 7433 | 4566 |
| 42" | ----- | IED42-2-3 | 48" | 2 | 1150 | 17315 | 87 | 280 | -- | 4895 |
| 48" | ----- | IED48-3-3 | 54" | 3 | 850 | 24280 | 86 | 360 | -- | 6862 |

Note: Products listed in this section are custom built and subject to 100% cancellation/restocking charges

Dimensions

| SIZE | BLADE DIAMETER | PANEL SIZE | DEPTH DIMENSION |
|------|----------------|------------|-----------------|
| 12" | 12" | 16" | 11" |
| 16" | 16" | 20" | 11" |
| 20" | 20" | 24" | 13" |
| 24" | 24" | 30" | 15" |
| 30" | 30" | 36" | 15" |
| 36" | 36" | 42" | 18" |
| 42" | 42" | 48" | 18" |
| 48" | 48" | 54" | 20" |

Note: Depth dimension varies with motor selection

Industrial Belt Drive Exhaust Fans

Features

- Totally enclosed motors:
 - 1-Phase motors are field convertible 115V / 230V
 - 3-Phase motors are field convertible 230V / 460V
 - Motors are set to lower voltage at the factory, unless a request is made at time of order to set to the higher voltage
- 16 gauge steel venturi with steel pipe bracing
- Steel blades
- Double pillow block bearing shaft support
- 1 year limited warranty



⚠ WARNING: This product can expose you to chemicals including nickel which is known to the State of California to cause cancer, and chromium, which is known to the State of California to cause birth defects and/or reproductive harm. For more information go to www.P65Warnings.ca.gov.

Options

- CES Shutters
- EMF Front Guard
- IBG Rear Guards

Standard Models

| BLADE SIZE | MFG MODEL NUMBER | | PANEL SIZE (Sq.) | HP | RPM | CFM | db's @ 10' | WT. (LBS) | LIST | |
|------------|------------------|-------------------|------------------|-------|------|-------|------------|-----------|------|------|
| | 1-PHASE | 3-PHASE | | | | | | | 1 PH | 3PH |
| | 115/230V-60Hz | 208/230/460v-60Hz | | | | | | | | |
| 24" | IE24-1/3 | IE24-1/3-3 | 30" | 1/3 | 825 | 5300 | 61 | 70 | 2902 | 2925 |
| | IE24-1/2 | IE24-1/2-3 | | 1/2 | 925 | 6200 | 66 | 75 | 2997 | 3014 |
| | IE24-3/4 | IE24-3/4-3 | | 3/4 | 1050 | 7000 | 71 | 82 | 3246 | 3047 |
| | IE24-1 | IE24-1-3 | | 1 | 1175 | 7800 | 73 | 90 | 3280 | 3124 |
| 30" | IE30-1/3 | IE30-1/3-3 | 36" | 1/3 | 570 | 7500 | 62 | 95 | 3036 | 3059 |
| | IE30-1/2 | IE30-1/2-3 | | 1/2 | 625 | 8500 | 64 | 95 | 3385 | 3155 |
| | IE30-3/4 | IE30-3/4-3 | | 3/4 | 725 | 10000 | 66 | 105 | 3390 | 3199 |
| | IE30-1 | IE30-1-3 | | 1 | 825 | 11000 | 70 | 115 | 3466 | 3309 |
| 36" | IE36-1/3 | IE36-1/3-3 | 42" | 1/3 | 425 | 9000 | 64 | 103 | 3341 | 3359 |
| | IE36-1/2 | IE36-1/2-3 | | 1/2 | 500 | 10500 | 66 | 105 | 3442 | 3466 |
| | IE36-3/4 | IE36-3/4-3 | | 3/4 | 575 | 11900 | 68 | 110 | 3745 | 3502 |
| | IE36-1 | IE36-1-3 | | 1 | 650 | 13100 | 70 | 120 | 3726 | 3570 |
| | IE36-1 1/2 | IE36-1 1/2-3 | | 1 1/2 | 750 | 15000 | 72 | 155 | 4259 | 4066 |
| | IE36-2 | IE36-2-3 | | 2 | 830 | 16500 | 74 | 165 | ---- | 4149 |
| 42" | IE42-3/4 | IE42-3/4-3 | 48" | 3/4 | 430 | 14000 | 67 | 175 | 4176 | 3986 |
| | IE42-1 | IE42-1-3 | | 1 | 490 | 15400 | 69 | 180 | 4207 | 4059 |
| | IE42-1 1/2 | IE42-1 1/2-3 | | 1 1/2 | 550 | 17200 | 71 | 185 | 4407 | 4220 |
| | IE42-2 | IE42-2-3 | | 2 | 620 | 19400 | 74 | 200 | --- | 4813 |
| | ----- | IE42-3-3 | | 3 | 700 | 22000 | 79 | 225 | ---- | 4979 |
| 48" | IE48-3/4 | IE48-3/4-3 | 54" | 3/4 | 350 | 17000 | 70 | 185 | 4570 | 4377 |
| | IE48-1 | IE48-1-3 | | 1 | 400 | 19100 | 71 | 190 | 4603 | 4451 |
| | IE48-1 1/2 | IE48-1 1/2-3 | | 1 1/2 | 460 | 22000 | 72 | 200 | 4793 | 4607 |
| | IE48-2 | IE48-2-3 | | 2 | 520 | 24000 | 74 | 250 | ---- | 5363 |
| | ----- | IE48-3-3 | | 3 | 590 | 27500 | 80 | 260 | ---- | 5529 |
| | ----- | IE48-5-3 | | 5 | 660 | 30500 | 83 | 280 | ---- | 5572 |
| 60" | IE60-2 | IE60-2-3 | 66" | 2 | 320 | 31000 | 77 | 320 | ---- | 7462 |
| | ----- | IE60-3-3 | | 3 | 370 | 35000 | 84 | 330 | ---- | 7626 |
| | ----- | IE60-5-3 | | 5 | 420 | 39000 | 86 | 350 | ---- | 7691 |

Note: Products listed in this section are custom built and subject to 100% cancellation/restocking charges

Dimensions

| SIZE | BLADE DIAMETER | PANEL SIZE | DEPTH DIMENSION |
|------|----------------|------------|-----------------|
| 24" | 24" | 30" | 18" |
| 30" | 30" | 36" | 18" |
| 36" | 36" | 42" | 20" |
| 42" | 42" | 48" | 20" |
| 48" | 48" | 54" | 22" |
| 60" | 60" | 66" | 28" |

Note: Depth dimension varies with motor selection

Heavy Duty Direct Drive Exhaust Fans

Features

- Totally enclosed and explosion proof motors
 - Explosion proof motors are Class 1, Div 1 Group D and Class 2, Div 1, Groups F & G
- Fans are shipped completely assembled
- Cast aluminum blades
- 14 gauge steel panel with welded steel pipe bracing
- 1 year limited warranty

⚠ WARNING: This product can expose you to chemicals including nickel which is known to the State of California to cause cancer, and chromium, which is known to the State of California to cause birth defects and/or reproductive harm. For more information go to www.P65Warnings.ca.gov.



Options

- CES Shutters
- EMF Front Guards
- IBG Rear Guards
- Acid Resistant Coating
- Reversed Air Flow
- Flat Front Venturi

Standard Models

| BLADE SIZE | MFG MODEL NUMBER | | PANEL SIZE (Sq.) | HP | RPM | CFM @ 1" SP | db's @ 10' | WT. (LBS) | LIST | | | |
|------------|------------------|-------------------|------------------|-------|------|-------------|------------|-----------|-------|-------|-------|-------|
| | 1-PHASE | 3-PHASE | | | | | | | TEC | | EXP* | |
| | 115/230V-60Hz | 208/230/460v-60Hz | | | | | | | 1 PH | 3 PH | 1 PH | 3 PH |
| 12" | EHD12-1/4 | EHD12-1/4-3 | 16" | 1/4 | 1725 | 1180 | 74 | 35 | 2115 | 2103 | 2649 | 2738 |
| 16" | EHD16-1/4 | EHD16-1/4-3 | 20" | 1/4 | 1725 | 2800 | 75 | 45 | 2580 | 2596 | 3115 | 3205 |
| 18" | EHD18-1/3 | EHD18-1/3-3 | 24" | 1/3 | 1725 | 3375 | 75 | 60 | 2738 | 2760 | 3437 | 3624 |
| | EHD18-1/2 | EHD18-1/2-3 | | 1/2 | 1725 | 4150 | 76 | 60 | 2857 | 2875 | 3677 | 3638 |
| 20" | EHD20-1/4 | EHD20-1/4-3 | 24" | 1/4 | 1725 | 3720 | 75 | 60 | 2619 | 2605 | 3158 | 3242 |
| | EHD20-1/2 | EHD20-1/2-3 | | 1/2 | 1725 | 4800 | 76 | 65 | 2821 | 2844 | 3645 | 3609 |
| | EHD20-1 | EHD20-1-3 | | 1 | 1725 | 6900 | 77 | 70 | 3152 | 3001 | 3939 | 4006 |
| 24" | EHD24-1/4 | EHD24-1/4-3 | 30" | 1/4 | 1725 | 5200 | 82 | 135 | 2777 | 2760 | 3314 | 3405 |
| | EHD24-1/3 | EHD24-1/3-3 | | 1/3 | 1150 | 4975 | 75 | 145 | 3359 | 3405 | 4499 | 4562 |
| | EHD24-1/2 | EHD24-1/2-3 | | 1/2 | 1725 | 6510 | 82 | 140 | 3077 | 3089 | 3894 | 3858 |
| | EHD24-3/4 | EHD24-3/4-3 | | 3/4 | 1725 | 6900 | 83 | 145 | 3323 | 3134 | 4150 | 3948 |
| | EHD24-1 | EHD24-1-3 | | 1 | 1725 | 7425 | 83 | 155 | 3414 | 3256 | 4203 | 4267 |
| | EHD24-2 | EHD24-2-3 | | 2 | 1725 | 9525 | 83 | 165 | 4306 | 3533 | ----- | 4713 |
| ----- | EHD24-3-3 | 3 | 1725 | 10500 | 85 | 170 | ----- | 3840 | ----- | 5099 | | |
| 30" | EHD30-1/3 | EHD30-1/3-3 | 36" | 1/3 | 1150 | 6950 | 79 | 145 | 3677 | 3722 | 4814 | 4886 |
| | EHD30-1/2 | EHD30-1/2-3 | | 1/2 | 1725 | 8980 | 89 | 135 | 3422 | 3437 | 4239 | 4203 |
| | EHD30-3/4 | EHD30-3/4-3 | | 3/4 | 1150 | 10440 | 79 | 175 | 4381 | 3909 | 5049 | 4899 |
| | ----- | EHD30-1-3 | | 1 | 870 | 10640 | 74 | 215 | ----- | 4831 | ----- | ----- |
| | EHD30-1 1/2 | EHD30-1 1/2-3 | | 1 1/2 | 1725 | 12000 | 89 | 165 | 3985 | 3789 | 6153 | 4958 |
| | EHD30-2 | EHD30-2-3 | | 2 | 1150 | 14000 | 82 | 215 | ----- | 4517 | ----- | 5857 |
| ----- | EHD30-3-3 | 3 | 1725 | 16000 | 89 | 190 | ----- | 4059 | ----- | 5311 | | |
| 36" | EHD36-1 | EHD36-1-3 | 42" | 1 | 1150 | 13600 | 84 | 225 | 6307 | 5040 | 7576 | 5979 |
| | ----- | EHD36-2-3 | | 2 | 1150 | 17620 | 84 | 250 | ----- | 5189 | ----- | 6533 |
| | ----- | EHD36-3-3 | | 3 | 1150 | 20500 | 85 | 255 | ----- | 5965 | ----- | 7545 |
| | ----- | EHD36-5-3 | | 5 | 1725 | 28000 | 94 | 250 | ----- | 5003 | ----- | 6376 |
| 42" | ----- | EHD42-1-3 | 48" | 1 | 870 | 15800 | 82 | 300 | ----- | 5857 | ----- | ----- |
| | EHD42-2 | EHD42-2-3 | | 2 | 1150 | 17964 | 88 | 260 | ----- | 5519 | ----- | 6863 |
| | ----- | EHD42-3-3 | | 3 | 1150 | 24500 | 88 | 270 | ----- | 6203 | ----- | 7784 |
| | ----- | EHD42-5-3 | | 5 | 1150 | 28970 | 88 | 285 | ----- | 6450 | ----- | 8707 |
| 48" | ----- | EHD48-3-3 | 54" | 3 | 1150 | 28600 | 92 | 290 | ----- | 7484 | ----- | 9068 |
| | ----- | EHD48-5-3 | | 5 | 1150 | 32000 | 94 | 305 | ----- | 7840 | ----- | 10102 |
| 60" | ----- | EHD60-3-3 | 66" | 3 | 1150 | 40000 | 97 | 700 | ----- | 9295 | ----- | 10873 |
| | ----- | EHD60-5-3 | | 5 | 1150 | 45000 | 97 | 730 | ----- | 10170 | ----- | 12436 |
| | ----- | EHD60-7 1/2-3 | | 7 1/2 | 870 | 47000 | 92 | 740 | ----- | 13357 | ----- | ----- |
| | ----- | EHD60-10-3 | | 10 | 870 | 57200 | 93 | 750 | ----- | 17899 | ----- | ----- |

Single Phase motors are field convertible 115V/230V. Three phase motors are field convertible 230V/460V.

Motors are set to lower voltage at the factory, unless a request is made at time of order to set to the higher voltage.

Note: Products listed in this section are custom built and subject to 100% cancellation/restocking charges

*Not all EXP motors are 208V capable

Dimensions

| SIZE | BLADE DIAMETER | PANEL SIZE | DEPTH DIMENSION |
|------|----------------|------------|-----------------|
| 12" | 12" | 16" | 11" |
| 16" | 16" | 20" | 11" |
| 20" | 20" | 24" | 13" |
| 24" | 24" | 30" | 15" |
| 30" | 30" | 36" | 15" |
| 36" | 36" | 42" | 18" |
| 42" | 42" | 48" | 18" |
| 48" | 48" | 54" | 20" |
| 60" | 60" | 66" | 22" |

Note: Depth dimension varies with motor selection

Heavy Duty Belt Drive Exhaust Fans

Features

- Totally enclosed and explosion proof motors
 - Explosion proof motors are Class 1, Div 1 Group D and Class 2, Div 1, Groups F & G
- Fans are shipped completely assembled
- Heavy gauge steel blades on TEC models
- Cast aluminum blades on EXP explosion proof models
- 14 gauge steel panel with welded steel pipe bracing
- 1 year limited warranty
- For optimum shutter efficiency, mount shutter 1/3 the distance of the fan opening size.
Example: 36" fan shutter would be mounted 12" from the fan blade

⚠ WARNING: This product can expose you to chemicals including nickel which is known to the State of California to cause cancer, and chromium, which is known to the State of California to cause birth defects and/or reproductive harm. For more information go to www.P65Warnings.ca.gov.

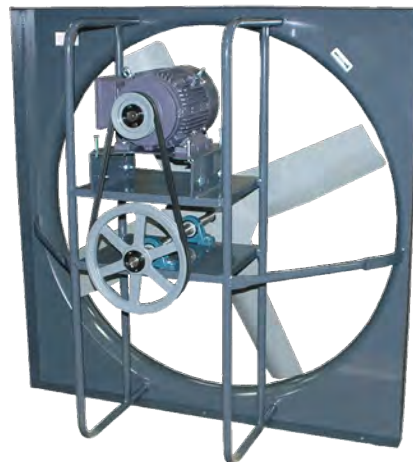

Options

- CES Shutters
- EMF Front Guards
- IBG Rear Guards
- Reversed Air Flow
- Flat Front Venturi

Standard Models

| BLADE SIZE | MFG MODEL NUMBER | | PANEL SIZE (Sq.) | HP | RPM | CFM 0" SP | db's @ 10" | WT. (LBS) | LIST | | | |
|------------|------------------|-------------------|------------------|-------|------|-----------|------------|-----------|------|------|-------|-------|
| | 1-PHASE | 3-PHASE | | | | | | | TEC | | EXP* | |
| | 115/230V-60Hz | 208/230/460v-60Hz | | | | | | | 1 PH | 3 PH | 1 PH | 3 PH |
| 24" | EHB24-1/4 | EHB24-1/4-3 | 30" | 1/4 | 780 | 4900 | 60 | 100 | 3498 | 3482 | 4750 | 4842 |
| | EHB24-1/2 | EHB24-1/2-3 | | 1/2 | 980 | 6219 | 66 | 130 | 3700 | 3714 | 5230 | 5185 |
| | EHB24-3/4 | EHB24-3/4-3 | | 3/4 | 1140 | 7090 | 71 | 140 | 3954 | 3751 | 5493 | 5289 |
| | EHB24-1 | EHB24-1-3 | | 1 | 1250 | 7180 | 73 | 140 | 4212 | 4051 | 5551 | 5626 |
| 30" | EHB30-1/4 | EHB30-1/4-3 | 36" | 1/4 | 540 | 7178 | 61 | 140 | 3730 | 3714 | 5224 | 5314 |
| | EHB30-1/3 | EHB30-1/3-3 | | 1/3 | 595 | 7909 | 63 | 150 | 3796 | 3820 | 5448 | 5634 |
| | EHB30-1/2 | EHB30-1/2-3 | | 1/2 | 640 | 8507 | 64 | 155 | 3894 | 3909 | 5696 | 5657 |
| | EHB30-3/4 | EHB30-3/4-3 | | 3/4 | 770 | 10235 | 66 | 165 | 4233 | 4030 | 6041 | 5837 |
| | EHB30-1 | EHB30-1-3 | | 1 | 975 | 10668 | 70 | 170 | 4449 | 4293 | 6091 | 6169 |
| | EHB30-1 1/2 | EHB30-1 1/2-3 | | 1 1/2 | 1140 | 12473 | 77 | 180 | 4643 | 4435 | 7688 | 6483 |
| 36" | EHB36-1/3 | EHB36-1/3-3 | 42" | 1/3 | 460 | 9113 | 64 | 160 | 4412 | 4435 | 5928 | 6114 |
| | EHB36-1/2 | EHB36-1/2-3 | | 1/2 | 530 | 10500 | 66 | 180 | 4518 | 4533 | 6309 | 6265 |
| | EHB36-3/4 | EHB36-3/4-3 | | 3/4 | 605 | 11985 | 68 | 200 | 4809 | 4615 | 6601 | 6400 |
| | EHB36-1 | EHB36-1-3 | | 1 | 665 | 13174 | 70 | 200 | 4842 | 4680 | 6611 | 6676 |
| | EHB36-1 1/2 | EHB36-1 1/2-3 | | 1 1/2 | 720 | 13660 | 72 | 210 | 5455 | 5261 | 8378 | 7166 |
| | EHB36-2 | EHB36-2-3 | | 2 | 870 | 16554 | 74 | 215 | 6025 | 5394 | ---- | 7428 |
| 42" | EHB42-1/3 | EHB42-1/3-3 | 48" | 1/3 | 335 | 10614 | 64 | 205 | 4591 | 4615 | 6483 | 6669 |
| | EHB42-1/2 | EHB42-1/2-3 | | 1/2 | 390 | 12343 | 65 | 210 | 4689 | 4705 | 6706 | 6676 |
| | EHB42-3/4 | EHB42-3/4-3 | | 3/4 | 435 | 14040 | 67 | 225 | 4998 | 4802 | 7098 | 6885 |
| | EHB42-1 | EHB42-1-3 | | 1 | 490 | 15429 | 69 | 230 | 5064 | 4905 | 7103 | 7166 |
| | EHB42-1 1/2 | EHB42-1 1/2-3 | | 1 1/2 | 550 | 17420 | 71 | 240 | 5268 | 5073 | 8723 | 7510 |
| | EHB42-2 | EHB42-2-3 | | 2 | 725 | 20653 | 74 | 245 | 6243 | 5610 | ---- | 7842 |
| | ---- | EHB42-3-3 | | 3 | 830 | 23645 | 79 | 250 | ---- | 5794 | ---- | 8087 |
| 48" | EHB48-1/2 | EHB48-1/2-3 | 54" | 1/2 | 330 | 15230 | 69 | 190 | 5800 | 5814 | 8064 | 8027 |
| | EHB48-3/4 | EHB48-3/4-3 | | 3/4 | 370 | 17339 | 70 | 195 | 6084 | 5889 | 8551 | 8349 |
| | EHB48-1 | EHB48-1-3 | | 1 | 410 | 19188 | 71 | 235 | 6123 | 5965 | 8559 | 8635 |
| | EHB48-1 1/2 | EHB48-1 1/2-3 | | 1 1/2 | 465 | 21731 | 72 | 245 | 6369 | 6175 | 10165 | 8949 |
| | EHB48-2 | EHB48-2-3 | | 2 | 520 | 24274 | 74 | 250 | 7390 | 6760 | ---- | 9239 |
| | ---- | EHB48-3-3 | | 3 | 680 | 28150 | 80 | 270 | ---- | 6954 | ---- | 9513 |
| | ---- | EHB48-5-3 | | 5 | 800 | 33160 | 83 | 285 | ---- | 7036 | ---- | 9699 |
| 60" | EHB60-1 | EHB60-1-3 | 66" | 1 | 280 | 23090 | 76 | 380 | 8537 | 8378 | 11567 | 11642 |
| | EHB60-1 1/2 | EHB60-1 1/2-3 | | 1 1/2 | 340 | 28068 | 77 | 390 | 8738 | 8546 | 13180 | 11971 |
| | EHB60-2 | EHB60-2-3 | | 2 | 390 | 32200 | 78 | 395 | 9247 | 8627 | ---- | 12130 |
| | ---- | EHB60-3-3 | | 3 | 450 | 37183 | 84 | 410 | ---- | 9047 | ---- | 12527 |
| | ---- | EHB60-5-3 | | 5 | 540 | 44600 | 86 | 420 | ---- | 9115 | ---- | 12706 |

Single Phase motors are field convertible 115V/230V. Three phase motors are field convertible 230V/460V.

Motors are set to lower voltage at the factory, unless a request is made at time of order to set to the higher voltage.

Note: Products listed in this section are custom built and subject to 100% cancellation/restocking charges.

*Not all EXP motors are 208V capable.

Dimensions

| SIZE | BLADE DIAMETER | PANEL SIZE | DEPTH DIMENSION |
|------|----------------|------------|-----------------|
| 24" | 24" | 30" | 16" |
| 30" | 30" | 36" | 16" |
| 36" | 36" | 42" | 18" |
| 42" | 42" | 48" | 20" |
| 48" | 48" | 54" | 21" |
| 60" | 60" | 66" | 26" |

Note: Depth dimension varies with motor selection.

Cabinet Exhaust Fans With Shutters

Features

- 120V, 1-Phase or 230 / 460V, 3-Phase, ball bearing, permanently lubricated, drip proof motor - UL listed
- Permanently lubricated bearings on blade drive shaft
- Aluminum blade
- Aluminum shutter
- 20 gauge powder coated venturi
- 18 gauge galvanized steel housing
- 1725 RPM motor
- Motor frame size 56 / Shaft: 5/8"
- Ships fully assembled
- Meets OSHA Standards
- 1 year warranty
- Made in U.S.A.

⚠ WARNING: This product can expose you to chemicals including nickel which is known to the State of California to cause cancer, and chromium, which is known to the State of California to cause birth defects and/or reproductive harm. For more information go to www.P65Warnings.ca.gov.



Standard Models

| SIZE | MOTOR HP | AMPS | | CFM | WT. (LBS) | 115V 1-PHASE | | | 230 / 460V 3-PHASE | | |
|------|-------------|------|-----------|--------|--------------|--------------------|------------------|-------------|--------------------|------------------|-------------|
| | | 115V | 230/460V | | | MFG CATALOG NUMBER | MFG MODEL NUMBER | LIST | MFG CATALOG NUMBER | MFG MODEL NUMBER | LIST |
| 24 | 1/3 | 5 | 1.9 / .9 | 10,000 | 100 | 08683902 | CBT-24B | 2069 | 08685202 | CBT-24B-3 | 2200 |
| 30 | 1/3 | 6 | 1.9 / .9 | 11,600 | 120 | 08684002 | CBT-30B | 2330 | 08685302 | CBT-30B-3 | 2499 |
| 36 | 1/2 | 8 | 2.3 / 1.1 | 14,000 | 135 | 08684102 | CBT-36B | 2629 | 08685402 | CBT-36B-3 | 2846 |
| 42 | 3/4 | 11 | 3.3 / 1.5 | 17,500 | 155 | 08684202 | CBT-42B | 3234 | 08685502 | CBT-42B-3 | 3489 |
| 48 | 1 | 15 | 3.8 / 1.9 | 23,500 | 200 | 08685102 | CBT-48B | 4007 | 08685002 | CBT-48B-3 | 4267 |

Dimensions

| SIZE | OUTSIDE DIMENSIONS | | | MAXIMUM REQUIRED INSIDE WALL OPENING |
|------|--------------------|---------|---------|--------------------------------------|
| | HEIGHT | WIDTH | DEPTH | |
| 24" | 28 1/4" | 28 1/4" | 22 1/2" | 28 3/4" x 28 3/4" |
| 30" | 34 1/4" | 34 1/4" | 22 1/2" | 34 1/2" x 34 1/2" |
| 36" | 40 1/4" | 40 1/4" | 18 1/2" | 40 1/2" x 40 1/2" |
| 42" | 48 1/2" | 48 1/2" | 18 1/2" | 48 3/4" x 48 3/4" |
| 48" | 54 1/2" | 54 1/2" | 21 1/2" | 54 3/4" x 54 3/4" |

Exhaust Fan Accessories - Heavy Duty Exhaust Shutter

Features

- Air open - Gravity close
- Aluminum construction
- Heavy duty blades
- Weather stripping for tighter seal
- For optimum shutter efficiency, mount shutter $\frac{1}{3}$ the distance of the fan opening size. Example: 36" fan shutter would be mounted 12" from the fan blade
- Shutter should be sized to fit exhaust opening
- For IE, IED, EHB and EHD models



WARNING: This product can expose you to chemicals including nickel which is known to the State of California to cause cancer, and chromium, which is known to the State of California to cause birth defects and/or reproductive harm. For more information go to www.P65Warnings.ca.gov.

Standard Models

| FAN SIZE | MFG CATALOG NUMBER | MFG MODEL NUMBER | INSIDE FRAME DIMENSIONS | OUTSIDE FRAME DIMENSIONS | WT. (LBS) | LIST |
|----------|--------------------|------------------|-------------------------|--------------------------|-----------|-------------|
| 12" | 07983302 | CES 12-HD | 12" x 12" | 14" x 15" | 4 | 191 |
| 16" | 08709102 | CES 16-HD | 16" x 16" | 19" x 19" | 7 | 230 |
| 18" | 08518902 | CES 18-HD | 18" x 18" | 21" x 21" | 8 | 264 |
| 20" | 08696602 | CES 20-HD | 20" x 20" | 23" x 23" | 9 | 270 |
| 24" | 08757202 | CES 24-HD | 24" x 24" | 27" x 27" | 11 | 329 |
| 30" | 08757302 | CES 30-HD | 30" x 30" | 33" x 33" | 15 | 402 |
| 36" | 08757402 | CES 36-HD | 36" x 36" | 39" x 39" | 19 | 704 |
| 42" | 08757502 | CES 42-HD | 42" x 42" | 45" x 45" | 23 | 896 |
| 48" | 08757602 | CES 48-HD | 48" x 48" | 51" x 51" | 28 | 1032 |
| 54" | 08775102 | CES 54-HD | 54" x 54" | 57" x 57" | 39 | 1166 |
| 60" | 07998702 | CES 60-HD | 60" x 60" | 63" x 63" | 47 | 1432 |

Heavy Duty Shutter Motor Kit Features



- Used to open shutter when shutter is used to provide make-up air (Shutter should be one size larger than exhaust fan size and should be located on opposite wall)
- Used for positive closure of exhaust shutter
- 115V or 230V, 60 HZ, 1-Phase

Standard Models

| MFG CATALOG NUMBER | MFG MODEL NUMBER | DESCRIPTION | WT. (LBS) | LIST |
|--------------------|------------------|---|-----------|------------|
| 07971002 | MK-1 | For shutter sizes 12" thru 30" (Single Panel) | 5 | 532 |
| 07971102 | MK-2 | For shutter sizes 36" thru 48" (Double Panel) | 8 | 704 |
| 08777102 | MK-3 | For shutter sizes 54" thru 72" (Double Panel) | 12 | 906 |

Motorized Supply Air Intake Shutter

Features

- Inward opening blades for use with intake fans when shutter is located directly in air stream
- Galvanized construction
- 115V or 230V, 60 HZ, 1-Phase
- For IE, IED, EHB and EHD models

Standard Models

| FAN SIZE | MFG CATALOG NUMBER | MFG MODEL NUMBER | ROUGH OPENING | OVERALL SIZE | WT. (LBS) | LIST |
|----------|--------------------|------------------|---------------|--------------|-----------|-------------|
| 24" | 08516902 | CESM-24 | 24" x 24" | 27" x 27" | 15 | 1361 |
| 30" | 08007102 | CESM-30 | 30" x 30" | 33" x 33" | 18 | 1589 |
| 36" | 08004602 | CESM-36 | 36" x 36" | 39" x 39" | 21 | 1736 |
| 42" | 08517202 | CESM-42 | 42" x 42" | 45" x 45" | 35 | 2834 |
| 48" | 07997202 | CESM-48 | 48" x 48" | 51" x 51" | 42 | 4004 |
| 60" | 07983002 | CESM-60 | 60" x 60" | 63" x 63" | 56 | 4721 |



WARNING: This product can expose you to chemicals including nickel which is known to the State of California to cause cancer, and chromium, which is known to the State of California to cause birth defects and/or reproductive harm. For more information go to www.P65Warnings.ca.gov.

Exhaust Fan Accessories - Fan Guards

Rear Box Guard Bolt Together With Wire Guards



⚠ WARNING: This product can expose you to chemicals including nickel which is known to the State of California to cause cancer, and chromium, which is known to the State of California to cause birth defects and/or reproductive harm. For more information go to www.P65Warnings.ca.gov.

Features

- For IE, IED, EHB and EHD models
- 1/4" Smaller than the panel size of the fan
- Meets OSHA requirements

Standard Models

| MFG MODEL NUMBER | FITS FAN SIZE | LIST |
|------------------|---------------|------|
| IBG-24 | 24" | 1191 |
| IBG-30 | 30" | 1255 |
| IBG-36 | 36" | 1509 |
| IBG-42 | 42" | 1583 |
| IBG-48 | 48" | 1940 |
| IBG-60 | 60" | 2994 |

Rear Expanded Metal Box Guard



⚠ WARNING: This product can expose you to chemicals including nickel which is known to the State of California to cause cancer, and chromium, which is known to the State of California to cause birth defects and/or reproductive harm. For more information go to www.P65Warnings.ca.gov.

Features

- For IE, IED, EHB and EHD models
- 1/4" Smaller than the panel size of the fan
- Meets OSHA requirements

Standard Models

| MFG MODEL NUMBER | FITS FAN SIZE | LIST |
|------------------|---------------|------|
| IBG-12 | 12" | 731 |
| IBG-16 | 16" | 731 |
| IBG-18 | 18" | 810 |
| IBG-20 | 20" | 810 |

Spiral Front and Rear Guards

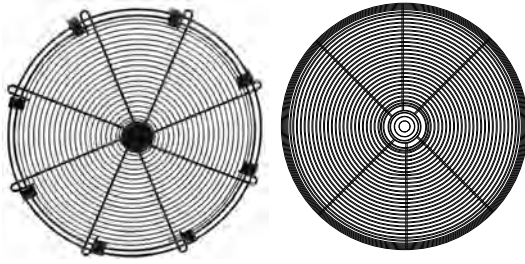

Spiral Front

Spiral Rear

⚠ WARNING: This product can expose you to chemicals including nickel which is known to the State of California to cause cancer, and chromium, which is known to the State of California to cause birth defects and/or reproductive harm. For more information go to www.P65Warnings.ca.gov.

Features

- For EHD models only
- Fits between motor and blade
- Rear guard installed at factory only
- Meets OSHA requirements

Standard Models

| MFG MODEL NUMBER | TYPE | FITS FAN SIZE | LIST |
|------------------|--------------|---------------|------|
| SF-12 | SPIRAL FRONT | 12" | 401 |
| SF-16 | | 16" | 431 |
| SF-18 | | 18" | 477 |
| SF-20 | | 20" | 488 |
| SF-24 | | 24" | 526 |
| SR-12 | SPIRAL REAR | 12" | 416 |
| SR-16 | | 16" | 442 |
| SR-18 | | 18" | 488 |
| SR-20 | | 20" | 505 |
| SR-24 | | 24" | 543 |

Expanded Metal Front Guard

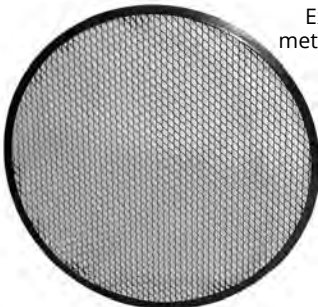

Expanded metal guard 60"

⚠ WARNING: This product can expose you to chemicals including nickel which is known to the State of California to cause cancer, and chromium, which is known to the State of California to cause birth defects and/or reproductive harm. For more information go to www.P65Warnings.ca.gov.

Features

- For EHB, EHD, IE, & IED models
- 1" Larger than blade size
- Meets OSHA requirements

Standard Models

| MFG MODEL NUMBER | FITS FAN SIZE | LIST |
|------------------|---------------|------|
| EMF-12 | 12" | 480 |
| EMF-16 | 16" | 497 |
| EMF-20 | 20" | 525 |
| EMF-24 | 24" | 551 |
| EMF-30 | 30" | 697 |
| EMF-36 | 36" | 862 |
| EMF-42 | 42" | 907 |
| EMF-48 | 48" | 990 |
| EMF-60 | 60" | 1494 |

Cabinet Exhaust Fan Package Option

With Bolt Together Rear Guard

Package Includes

- Wall collar
- Automatic shutter
- Rear box guard

Features

- For IE, IED, EHB and EHD models
- Wall collar OD is ¼" larger than fan panel size
- Meets OSHA requirements

Standard Models

| MFG MODEL NUMBER | FAN SIZE | LIST |
|------------------|----------|------|
| CEFP-24 | 24" | 2126 |
| CEFP-30 | 30" | 2401 |
| CEFP-36 | 36" | 2982 |
| CEFP-42 | 42" | 3427 |
| CEFP-48 | 48" | 4091 |



⚠ WARNING: This product can expose you to chemicals including nickel which is known to the State of California to cause cancer, and chromium, which is known to the State of California to cause birth defects and/or reproductive harm. For more information go to www.P65Warnings.ca.gov.

With Expanded Metal Rear Guard

Package Includes

- Wall collar
- Automatic shutter
- Rear box guard

Features

- For IE, IED, EHB and EHD models
- Wall collar OD is ¼" larger than fan panel size
- Meets OSHA requirements

Standard Models

| MFG MODEL NUMBER | FAN SIZE | LIST |
|------------------|----------|------|
| CEFP-12 | 12" | 1331 |
| CEFP-16 | 16" | 1421 |
| CEFP-18 | 18" | 1604 |
| CEFP-20 | 20" | 1665 |
| CEFP-60 | 60" | 6143 |

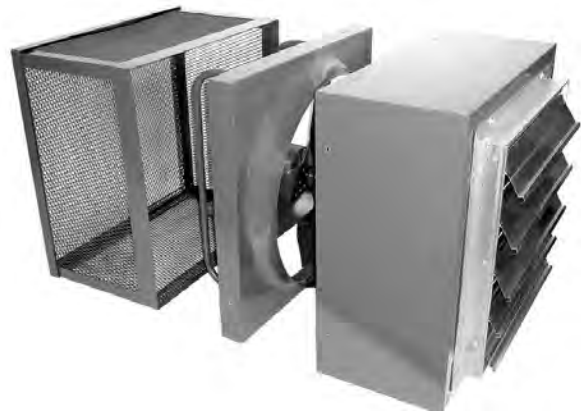

⚠ WARNING: This product can expose you to chemicals including nickel which is known to the State of California to cause cancer, and chromium, which is known to the State of California to cause birth defects and/or reproductive harm. For more information go to www.P65Warnings.ca.gov.

Exterior Weather Hood Option

Features

- For IE, IED, EHB and EHD models.
- Galvanized housing with ½ - 16 expanded metal bird screen
- Can be used for intake or exhaust
- Meets OSHA requirements

Standard Models

| MFG MODEL NUMBER | FAN SIZE | LIST |
|------------------|----------|------|
| WH-12 | 12" | 1338 |
| WH-16 | 16" | 1395 |
| WH-18 | 18" | 1425 |
| WH-20 | 20" | 1449 |
| WH-24 | 24" | 2060 |
| WH-30 | 30" | 2145 |
| WH-36 | 36" | 2661 |
| WH-42 | 42" | 2765 |
| WH-48 | 48" | 3199 |
| WH-60 | 60" | 4278 |

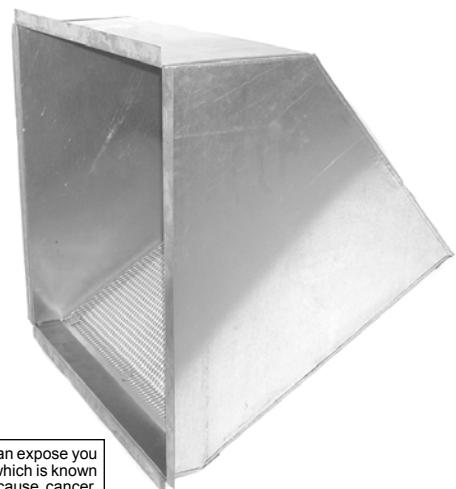

⚠ WARNING: This product can expose you to chemicals including nickel which is known to the State of California to cause cancer, and chromium, which is known to the State of California to cause birth defects and/or reproductive harm. For more information go to www.P65Warnings.ca.gov.

Insulated Roof Curbs

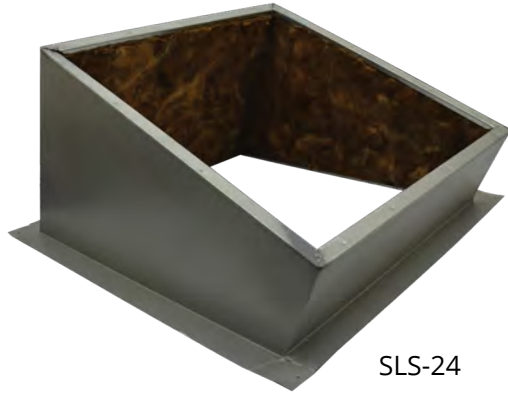

SLS-24

Features

- Used with UEB, UED, and RE roof ventilators
- For flat, single slope or ridge style roofs
- Galvanized steel construction
- 1 1/2" insulated thickness, 3 pounds density
- 8" height overall
- Not for corrugated roofs

⚠ WARNING: This product can expose you to chemicals including nickel which is known to the State of California to cause cancer, and chromium, which is known to the State of California to cause birth defects and/or reproductive harm. For more information go to www.P65Warnings.ca.gov.

Standard Models

| FAN | MFG MODEL NUMBER | | | BASE DIMENSION | OVERALL DIMENSION | LIST | | |
|-----|------------------|--------|--------|----------------|-------------------|-------------|-------------|-------------|
| | FLAT | SLOPE | RIDGE | | | FLAT | SLOPE | RIDGE |
| 18" | FLS-18 | SLS-18 | RDS-18 | 32" x 32" | 44" x 44" | 637 | 1229 | 1449 |
| 24" | FLS-24 | SLS-24 | RDS-24 | 38" x 38" | 50" x 50" | 736 | 1406 | 1650 |
| 30" | FLS-30 | SLS-30 | RDS-30 | 44" x 44" | 56" x 56" | 832 | 1575 | 1861 |
| 36" | FLS-36 | SLS-36 | RDS-36 | 50" x 50" | 62" x 62" | 907 | 1727 | 1989 |
| 42" | FLS-42 | SLS-42 | RDS-42 | 56" x 56" | 68" x 68" | 1000 | 1895 | 2244 |
| 48" | FLS-48 | SLS-48 | RDS-48 | 62" x 62" | 74" x 74" | 1346 | 2547 | 3019 |
| 54" | FLS-54 | SLS-54 | RDS-54 | 68" x 68" | 80" x 80" | 1467 | 2768 | 3277 |
| 60" | FLS-60 | SLS-60 | RDS-60 | 74" x 74" | 86" x 86" | 1592 | 3012 | 3564 |

Back Draft Dampers to Fit in Curb

UEB and UED models require higher curb height when used with back draft damper; consult factory

| FAN SIZE | MFG MODEL NUMBER | SHUTTER SIZE | LIST |
|----------|------------------|--------------|-------------|
| 18" | CD-18 | 28" x 28" | 843 |
| 24" | CD-24 | 34" x 34" | 985 |
| 30" | CD-30 | 40" x 40" | 1358 |
| 36" | CD-36 | 46" x 46" | 1677 |
| 42" | CD-42 | 52" x 52" | 1852 |
| 48" | CD-48 | 58" x 58" | 2247 |
| 54" | CD-54 | 64" x 64" | 2818 |
| 60" | CD-60 | 70" x 70" | 3063 |

Motor Kit for Dampers

115V or 230V, 60Hz, 1-Phase. (Specify Voltage)

| MFG MODEL NUMBER | DESCRIPTION | WT. (LBS) | LIST |
|------------------|--------------------------------|-----------|------------|
| DMKP1 | For shutter sizes 18" thru 36" | 5 | 770 |
| DMKP2 | For shutter sizes 42" thru 60" | 8 | 918 |

Belt Drive Hooded Roof Ventilators



CLOSED

WARNING: This product can expose you to chemicals including nickel which is known to the State of California to cause cancer, and chromium, which is known to the State of California to cause birth defects and/or reproductive harm. For more information go to www.P65Warnings.ca.gov.



OPEN

Features

- Used for exhaust or intake
- Heavy industrial steel base with aluminum hood
- Steel blades
- Bird screen included
- No back draft protection in standard construction Dampers offered as optional accessory
- 1 year limited warranty

Options

- Direct drive
- Protective coatings
- Roof curb
- Filters

Dimensions

| SIZE | MINIMUM ROOF HOLE (SQUARE) | HOLE LENGTH x WIDTH | HOOD HEIGHT | ROOF CURB O.D. (SQUARE) |
|------|----------------------------|---------------------|-------------|-------------------------|
| 24" | 30" | 54" x 64" | 30" | 39" |
| 30" | 36" | 60" x 76" | 36" | 45" |
| 36" | 42" | 72" x 82" | 40" | 51" |
| 42" | 48" | 80" x 89" | 43" | 57" |
| 48" | 54" | 87" x 95" | 46" | 63" |
| 54" | 60" | 92" x 98" | 54" | 69" |
| 60" | 66" | 90" x 107" | 56" | 75" |

Standard Models

| BLADE SIZE | 1-PHASE 115/230V | 3-PHASE 208/230/460v | HP | RPM | C.F.M. - STATIC PRESSURE | | | | Db's @ 10' | WT. (LBS) | LIST | | | |
|------------|---------------------|-------------------------|-----|------|--------------------------|-------|-------|-------|---------------|--------------|--------------|--------------|--------------|--------------|
| | | | | | MFG MODEL NUMBER | | | | | | EXHAUST | | INTAKE | |
| | | | | | 0" | 1/8" | 1/4" | 1/2" | | | 1 PH | 3 PH | 1 PH | 3 PH |
| 24" | RE24-1/4 | RE24-1/4-3 | 1/4 | 780 | 4900 | 4222 | 2807 | 800 | 60 | 340 | 8019 | 7985 | 8019 | 7985 |
| | RE24-1/2 | RE24-1/2-3 | 1/2 | 980 | 6219 | 5716 | 5061 | 2600 | 66 | 350 | 8310 | 8224 | 8310 | 8224 |
| | RE24-3/4 | RE24-3/4-3 | 3/4 | 1140 | 7090 | 6648 | 6144 | 4413 | 71 | 360 | 8488 | 8354 | 8488 | 8354 |
| | RE24-1 | RE24-1-3 | 1 | 1250 | 7180 | 6696 | 6271 | 4464 | 73 | 365 | 8949 | 8694 | 8949 | 8694 |
| 30" | RE30-1/3 | RE30-1/3-3 | 1/3 | 595 | 7909 | 6380 | 3617 | 767 | 60 | 385 | 9308 | 9257 | 9308 | 9257 |
| | RE30-1/2 | RE30-1/2-3 | 1/2 | 640 | 8507 | 7170 | 4486 | 1373 | 64 | 385 | 9451 | 9366 | 9451 | 9366 |
| | RE30-3/4 | RE30-3/4-3 | 3/4 | 770 | 10235 | 9192 | 7657 | 3833 | 66 | 400 | 9776 | 9640 | 9776 | 9640 |
| | RE30-1 | RE30-1-3 | 1 | 975 | 10668 | 9959 | 8626 | 5184 | 70 | 400 | 10100 | 9843 | 10100 | 9843 |
| 36" | RE30-1 1/2 | RE30-1 1/2-3 | 1.5 | 1140 | 12473 | 11867 | 11112 | 8135 | 77 | 410 | 10304 | 9921 | 10304 | 9921 |
| | RE36-1/3 | RE36-1/3-3 | 1/3 | 460 | 9113 | 6992 | 3722 | 486 | 64 | 425 | 11279 | 11226 | 11279 | 11226 |
| | RE36-1/2 | RE36-1/2-3 | 1/2 | 530 | 10500 | 8821 | 5985 | 2084 | 66 | 425 | 11416 | 11328 | 11416 | 11328 |
| | RE36-3/4 | RE36-3/4-3 | 3/4 | 605 | 11985 | 10583 | 8563 | 4017 | 68 | 435 | 11643 | 11509 | 11643 | 11509 |
| | RE36-1 | RE36-1-3 | 1 | 665 | 13174 | 11932 | 10299 | 5729 | 70 | 440 | 11907 | 11651 | 11907 | 11651 |
| | RE36-1 1/2 | RE36-1 1/2-3 | 1.5 | 720 | 13660 | 12012 | 9579 | 5000 | 72 | 440 | 12375 | 11950 | 12375 | 11950 |
| 42" | RE36-2 | RE36-2-3 | 2 | 870 | 16554 | 15376 | 14088 | 9691 | 74 | 455 | 13297 | 12575 | 13297 | 12575 |
| | RE42-1/2 | RE42-1/2-3 | 1/2 | 390 | 12343 | 9352 | 4957 | 1642 | 65 | 540 | 12651 | 12564 | 12651 | 12564 |
| | RE42-3/4 | RE42-3/4-3 | 3/4 | 435 | 14040 | 11530 | 7633 | 3311 | 67 | 545 | 13095 | 12959 | 13095 | 12959 |
| | RE42-1 | RE42-1-3 | 1 | 490 | 15429 | 13194 | 10438 | 4668 | 69 | 555 | 13358 | 13103 | 13358 | 13103 |
| | RE42-1 1/2 | RE42-1 1/2-3 | 1.5 | 550 | 17420 | 15421 | 13117 | 7289 | 71 | 560 | 13623 | 13197 | 13623 | 13197 |
| | RE42-2 | RE42-2-3 | 2 | 725 | 20653 | 19128 | 17503 | 11319 | 74 | 570 | 14451 | 13733 | 14451 | 13733 |
| 48" | ----- | RE42-3-3 | 3 | 830 | 23645 | 22296 | 20984 | 17290 | 79 | 585 | ---- | 13906 | ---- | 13906 |
| | RE48-3/4 | RE48-3/4-3 | 3/4 | 370 | 17339 | 13700 | 7389 | 2244 | 70 | 650 | 15355 | 15219 | 15355 | 15219 |
| | RE48-1 | RE48-1-3 | 1 | 410 | 19188 | 16078 | 10903 | 4037 | 71 | 660 | 15627 | 15371 | 15627 | 15371 |
| | RE48-1 1/2 | RE48-1 1/2-3 | 1.5 | 465 | 21731 | 19010 | 14991 | 7081 | 72 | 665 | 15866 | 15441 | 15866 | 15441 |
| | RE48-2 | RE48-2-3 | 2 | 520 | 24274 | 21943 | 19080 | 10125 | 74 | 680 | 16779 | 16053 | 16779 | 16053 |
| | ----- | RE48-3-3 | 3 | 680 | 28150 | 25683 | 23615 | 16930 | 80 | 700 | ---- | 16256 | ---- | 16256 |
| 54" | ----- | RE48-5-3 | 5 | 800 | 33160 | 30900 | 29290 | 25000 | 83 | 720 | ---- | 16386 | ---- | 16386 |
| | RE54-1 | RE54-1-3 | 1 | 410 | 23130 | 20588 | 17500 | 9600 | 73 | 910 | 18594 | 18337 | 18594 | 18337 |
| | RE54-1 1/2 | RE54-1 1/2-3 | 1.5 | 450 | 25400 | 22600 | 19300 | 10316 | 75 | 920 | 18969 | 18544 | 18969 | 18544 |
| | RE54-2 | RE54-2-3 | 2 | 480 | 27200 | 24312 | 20660 | 11010 | 76 | 930 | 19448 | 18723 | 19448 | 18723 |
| | ----- | RE54-3-3 | 3 | 550 | 31213 | 28722 | 25830 | 15420 | 77 | 940 | ---- | 19064 | ---- | 19064 |
| 60" | ----- | RE54-5-3 | 5 | 660 | 37458 | 35238 | 32893 | 26538 | 80 | 960 | ---- | 19208 | ---- | 19208 |
| | RE60-1 | RE60-1-3 | 1 | 250 | 23090 | 19161 | 12850 | ---- | 76 | 1150 | 19567 | 19312 | 19567 | 19312 |
| | RE60-1 1/2 | RE60-1 1/2-3 | 1.5 | 340 | 28068 | 23283 | 15624 | 8000 | 77 | 1150 | 20318 | 19890 | 20318 | 19890 |
| | RE60-2 | RE60-2-3 | 2 | 390 | 32200 | 26710 | 17924 | 9380 | 78 | 1200 | 20763 | 20037 | 20763 | 20037 |
| | ----- | RE60-3-3 | 3 | 450 | 37183 | 32356 | 25324 | 15013 | 84 | 1220 | ---- | 20388 | ---- | 20388 |
| 60" | ----- | RE60-5-3 | 5 | 540 | 44600 | 41232 | 35819 | 23237 | 86 | 1240 | ---- | 20514 | ---- | 20514 |
| | ----- | RE60-7 1/2-3 | 7.5 | 620 | 50184 | 47603 | 43981 | 32880 | 89 | 1285 | ---- | 21238 | ---- | 21238 |

Note: Products listed in this section are custom built and subject to 100% cancellation/restocking charges

Direct Drive Roof Ventilators



⚠ WARNING: This product can expose you to chemicals including nickel which is known to the State of California to cause cancer, and chromium, which is known to the State of California to cause birth defects and/or reproductive harm. For more information go to www.P65Warnings.ca.gov.

Features

- Cast Aluminum blades on most models
- Totally enclosed and explosion proof motors
- 1-Phase motors are field convertible 115V/230V
- 3-Phase motors are field convertible 230V/460V
- Motors are set to lower voltage at the factory unless a request is made at time of order to set them to the higher voltage
- Explosion proof motors are Class 1, Div 1, Group D and Class 2, Div 1, Groups F & G
- Wind band is 18 gauge galvanized steel
- Rubber shim under dampers for better seal
- Size of roof opening to be 6" larger than fan size
- Some models available with low R.P.M. motor for quieter operation
- 1 year limited warranty

Options

- Protective coating
- Prefabricated curbs
- Disconnect switch

Standard Models

| BLADE SIZE | 1-PHASE 115/230V | 3-PHASE 208/230/460v | HP | RPM | C.F.M - STATIC PRESSURE | | | | Db's @ 10' | WT. (LBS) | LIST | | | |
|------------|---------------------|-------------------------|-----|------|-------------------------|-------|-------|-------|---------------|--------------|-------|-------|-------|-------|
| | | | | | MFG MODEL NUMBER | | | | | | TEC | | EXP* | |
| | | | | | 0" | 1/8" | 1/4" | 1/2" | | | 1 PH | 3 PH | 1 PH | 3 PH |
| 18" | UED18-1/4 | UED18-1/4-3 | 1/4 | 1140 | 2570 | 2263 | 1673 | 854 | 66 | 170 | 5972 | 5997 | 6376 | 6722 |
| | UED18-1/3 | UED18-1/3-3 | 1/3 | 1725 | 3375 | 3000 | 2600 | 1400 | 75 | 175 | 5526 | 5515 | 6386 | 6570 |
| | UED18-1/2 | UED18-1/2-3 | 1/2 | 1725 | 4133 | 3938 | 3724 | 3132 | 76 | 180 | 5674 | 5651 | 6544 | 6704 |
| | UED18-1 | UED18-1-3 | 1 | 1725 | 4600 | 4375 | 4080 | 3000 | 77 | 190 | 6325 | 6189 | 7209 | 7278 |
| 24" | UED24-1/4 | UED24-1/4-3 | 1/4 | 1725 | 5200 | 4200 | 2820 | ---- | 75 | 240 | 6179 | 6209 | 6586 | 6931 |
| | UED24-3/4 | UED24-3/4-3 | 3/4 | 1140 | 6900 | 6450 | 6265 | 3300 | 76 | 260 | 7481 | 7176 | 8339 | 8272 |
| | UED24-1 | UED24-1-3 | 1 | 1725 | 7425 | 7000 | 6350 | 5000 | 83 | 280 | 6746 | 6628 | 7639 | 7723 |
| | ----- | UED24-3-3 | 3 | 1725 | 10500 | 9800 | 9500 | 8700 | 85 | 295 | ----- | 7117 | ----- | 8458 |
| 30" | UED30-3/4 | UED30-3/4-3 | 3/4 | 1140 | 10440 | 9750 | 8750 | 6000 | 79 | 310 | 7832 | 7317 | 8694 | 8636 |
| | ----- | UED30-1-3 | 1 | 870 | 10800 | 10100 | 9100 | 6360 | 74 | 330 | ----- | 8507 | ----- | ----- |
| | UED30-1 1/2 | UED30-1 1/2-3 | 1.5 | 1140 | 10410 | 9686 | 8834 | 6420 | 81 | 325 | 10833 | 8020 | ----- | 9132 |
| | UED30-2 | UED30-2-3 | 2 | 1140 | 14000 | 13750 | 12900 | 10450 | 82 | 335 | 13060 | 8214 | ----- | 9402 |
| | ----- | UED30-3-3 | 3 | 1725 | 16000 | 15350 | 14700 | 12900 | 89 | 335 | ----- | 7498 | ----- | 8846 |
| 36" | UED36-2 | UED36-2-3 | 2 | 1140 | 17620 | 16500 | 15200 | 12300 | 84 | 430 | 14527 | 9731 | ----- | 10919 |
| | ----- | UED36-3-3 | 3 | 1140 | 20500 | 19500 | 18500 | 15850 | 85 | 455 | ----- | 10319 | ----- | 12269 |
| | ----- | UED36-5-3 | 5 | 1140 | 22600 | 21700 | 20500 | 19000 | 87 | 465 | ----- | 11015 | ----- | 13212 |
| 42" | UED42-2 | UED42-2-3 | 2 | 1140 | 17964 | 17277 | 15326 | 12351 | 88 | 500 | 15514 | 10739 | ----- | 11924 |
| | ----- | UED42-5-3 | 5 | 1140 | 28970 | 27960 | 26840 | 24200 | 89 | 500 | ----- | 11972 | ----- | 14166 |
| 48" | ----- | UED48-3-3 | 3 | 1140 | 28600 | 26500 | 24400 | 20000 | 92 | 550 | ----- | 12924 | ----- | 14234 |
| | ----- | UED48-5-3 | 5 | 870 | 33000 | 31500 | 29750 | 25300 | 86 | 665 | ----- | 15428 | ----- | ----- |
| | ----- | UED48-7 1/2-3 | 7.5 | 1140 | 37000 | 35100 | 32800 | 28000 | 94 | 740 | ----- | 15498 | ----- | 18296 |
| | ----- | UED48-10-3 | 10 | 1140 | 41000 | 39200 | 38300 | 35400 | 95 | 875 | ----- | 16315 | ----- | 19291 |
| 60" | ----- | UED60-5-3 | 5 | 870 | 45200 | 41500 | 37000 | 26000 | 90 | 940 | ----- | 20389 | ----- | ----- |
| | ----- | UED60-7 1/2-3 | 7.5 | 870 | 47000 | 45500 | 43600 | 38700 | 92 | 950 | ----- | 21811 | ----- | ----- |

Note: Products listed in this section are custom built and subject to 100% cancellation/restocking charges

*Not all EXP motors are 208v capable

Dimensions

| SIZE | MINIMUM ROOF HOLE SIZE (SQUARE) | WIND BAND OUTER DIMENSION | ROOF CURB OUTER DIMENSION (SQUARE) | WIND BAND HEIGHT |
|------|---------------------------------|---------------------------|------------------------------------|------------------|
| 18" | 28" | 24" | 33" | 16" |
| 24" | 34" | 30" | 39" | 19" |
| 30" | 40" | 36" | 45" | 22" |
| 36" | 46" | 42" | 51" | 25" |
| 42" | 52" | 48" | 57" | 27" |
| 48" | 58" | 54" | 63" | 30" |
| 60" | 70" | 66" | 75" | 42" |

Belt Drive Roof Ventilators

Features

- Standard blades are heavy gauge steel
- Totally enclosed motors
- 1-Phase motors are field convertible 115V/230V
- 3-Phase motors are field convertible 230V/460V
- Motors are set to lower voltage at factory unless a request is made at time of order to set them to the higher voltage
- Wind band is 18 gauge galvanized steel
- Galvanized steel butterfly damper with rubber stops and seals
- Size of the roof opening to be 6" larger than fan size (Wind Band O.D.) dimension
- 1 year limited warranty



WARNING: This product can expose you to chemicals including nickel which is known to the State of California to cause cancer, and chromium, which is known to the State of California to cause birth defects and/or reproductive harm. For more information go to www.P65Warnings.ca.gov.

Options

- Protective coating
- Prefabricated curbs
- Disconnect switch

Standard Models

| BLADE SIZE | 1-PHASE 115/230V | 3-PHASE 208/230/460v | HP | RPM | C.F.M - STATIC PRESSURE | | | | Db's @ 10' | WT. (LBS) | LIST | |
|------------|---------------------|-------------------------|-----|------|-------------------------|-------|-------|-------|---------------|--------------|--------------|--------------|
| | | | | | MFG MODEL NUMBER | | | | | | TEC | |
| | | | | | 0" | 1/8" | 1/4" | 1/2" | | | 1 PH | 3 PH |
| 24" | UEB24-1/3 | UEB24-1/3-3 | 1/3 | 780 | 4900 | 4222 | 2807 | 800 | 64 | 300 | 6713 | 6704 |
| | UEB24-1/2 | UEB24-1/2-3 | 1/2 | 980 | 6219 | 5716 | 5661 | 2600 | 66 | 305 | 6915 | 6891 |
| | UEB24-3/4 | UEB24-3/4-3 | 3/4 | 1140 | 7090 | 6648 | 6144 | 4413 | 71 | 310 | 7151 | 7026 |
| 30" | UEB30-1/2 | UEB30-1/2-3 | 1/2 | 640 | 8507 | 7170 | 4486 | 1373 | 64 | 350 | 7237 | 7209 |
| | UEB30-3/4 | UEB30-3/4-3 | 3/4 | 770 | 10235 | 9192 | 7657 | 3833 | 66 | 360 | 7624 | 7488 |
| | UEB30-1 | UEB30-1-3 | 1 | 975 | 10668 | 9959 | 8626 | 5184 | 70 | 370 | 8121 | 8043 |
| 36" | UEB36-1/2 | UEB36-1/2-3 | 1/2 | 530 | 10500 | 8821 | 5985 | 2084 | 66 | 360 | 8550 | 8526 |
| | UEB36-3/4 | UEB36-3/4-3 | 3/4 | 605 | 11985 | 10583 | 8563 | 4017 | 68 | 370 | 9031 | 8896 |
| | UEB36-1 | UEB36-1-3 | 1 | 665 | 13174 | 11932 | 10299 | 5729 | 70 | 390 | 9367 | 9332 |
| | UEB36-1 1/2 | UEB36-1 1/2-3 | 1.5 | 720 | 13660 | 12012 | 9579 | 5000 | 72 | 395 | 9753 | 9597 |
| 42" | UEB42-3/4 | UEB42-3/4-3 | 3/4 | 435 | 14040 | 11530 | 7633 | 3311 | 67 | 455 | 9841 | 9705 |
| | UEB42-1 | UEB42-1-3 | 1 | 490 | 15429 | 13194 | 10438 | 4668 | 69 | 465 | 10254 | 10238 |
| | UEB42-1 1/2 | UEB42-1 1/2-3 | 1.5 | 550 | 17420 | 15421 | 13117 | 7289 | 71 | 470 | 10861 | 10701 |
| | UEB42-2 | UEB42-2-3 | 2 | 725 | 20653 | 19128 | 17503 | 11319 | 74 | 485 | 11637 | 11207 |
| | ----- | UEB42-3-3 | 3 | 830 | 23645 | 22296 | 20984 | 17290 | 79 | 495 | ---- | 11367 |
| 48" | UEB48-3/4 | UEB48-3/4-3 | 3/4 | 370 | 17339 | 13700 | 7389 | 2244 | 70 | 505 | 11382 | 11255 |
| | UEB48-1 | UEB48-1-3 | 1 | 410 | 19188 | 16078 | 10903 | 4037 | 71 | 520 | 11727 | 11645 |
| | UEB48-1 1/2 | UEB48-1 1/2-3 | 1.5 | 465 | 21731 | 19010 | 14991 | 7081 | 72 | 535 | 11930 | 11803 |
| | UEB48-2 | UEB48-2-3 | 2 | 520 | 24274 | 21943 | 19080 | 10125 | 74 | 545 | 13047 | 12648 |
| | ----- | UEB48-3-3 | 3 | 680 | 28150 | 25683 | 23615 | 16930 | 80 | 560 | ---- | 12859 |
| 54" | UEB54-1 | UEB54-1-3 | 1 | 410 | 23130 | 20588 | 17500 | 9600 | 73 | 870 | 15921 | 15785 |
| | UEB54-1 1/2 | UEB54-1 1/2-3 | 1.5 | 450 | 25400 | 22600 | 19300 | 10316 | 75 | 880 | 16281 | 16140 |
| | UEB54-2 | UEB54-2-3 | 2 | 480 | 27200 | 24312 | 20660 | 11010 | 76 | 890 | 16737 | 16365 |
| | ----- | UEB54-3-3 | 3 | 550 | 31213 | 28722 | 25830 | 15420 | 80 | 900 | ---- | 16948 |
| | ----- | UEB54-5-3 | 5 | 660 | 37458 | 35238 | 32843 | 26538 | 82 | 920 | ---- | 17133 |
| 60" | UEB60-1 1/2 | UEB60-1 1/2-3 | 1.5 | 340 | 28068 | 23203 | 15624 | 8000 | 78 | 940 | 17327 | 17183 |
| | UEB60-2 | UEB60-2-3 | 2 | 390 | 32200 | 26710 | 17924 | 9380 | 80 | 960 | 17707 | 17344 |
| | ----- | UEB60-3-3 | 3 | 450 | 37183 | 32356 | 25324 | 15013 | 84 | 985 | ---- | 18244 |
| | ----- | UEB60-5-3 | 5 | 540 | 44600 | 41232 | 35819 | 23237 | 86 | 1000 | ---- | 18414 |

Note: Products listed in this section are custom built and subject to 100% cancellation/restocking charges

Dimensions

| SIZE | MINIMUM ROOF HOLE SIZE (SQUARE) | WIND BAND OUTER DIMENSION | ROOF CURB OUTER DIMENSION (SQUARE) | WIND BAND HEIGHT |
|------|---------------------------------|---------------------------|------------------------------------|------------------|
| 24" | 34" | 30" | 39" | 19" |
| 30" | 40" | 36" | 45" | 22" |
| 36" | 46" | 42" | 51" | 25" |
| 42" | 52" | 48" | 57" | 27" |
| 48" | 58" | 54" | 63" | 30" |
| 54" | 64" | 60" | 69" | 36" |
| 60" | 70" | 66" | 75" | 42" |

Tubeaxial Direct Drive Duct Fans



Features

- Totally enclosed and explosion proof motors
- 1-Phase motors are field convertible 115V/230V
- 3-Phase motors are field convertible 230V/460V
- Motors are set to lower voltage at the factory unless a request is made at time of order to set them to the higher voltage
- Explosion proof motors are Class 1, Div 1, Group D and Class 2, Div 1, Groups F & G
- 14 gauge steel drum including mounting flanges
- Fan can be mounted to operate in any position
- Rugged cast aluminum blade, non-sparking
- 1 year limited warranty

Dimensions

| SIZE | HOUSING I.NNER DIM. | HOUSING OUTER DIM. | BOLT HOLE CENTERS | HOUSING DEPTH |
|------|---------------------|--------------------|-------------------|---------------|
| 12" | 12" | 14" | 13 1/8" | 14" |
| 18" | 18" | 20" | 19 1/8" | 14" |
| 24" | 24" | 27" | 25 3/4" | 18" |
| 27" | 27" | 30" | 28 3/4" | 18" |
| 30" | 30" | 33" | 31 3/4" | 18" |
| 34" | 34" | 37" | 35 3/4" | 18" |
| 42" | 42" | 45" | 43 9/16" | 18" |
| 48" | 48" | 51" | 49 5/8" | 18" |

⚠ WARNING: This product can expose you to chemicals including nickel which is known to the State of California to cause cancer, and chromium, which is known to the State of California to cause birth defects and/or reproductive harm. For more information go to www.P65Warnings.ca.gov.

Options

- Companion flanges
- Fan guards
- Protective coating
- Access doors

Standard Models

| BLADE SIZE | 1-PHASE 115/230V | | 3-PHASE 230/460v | | HP | RPM | BLADES | C.F.M - STATIC PRESSURE | | | | Db's @ 10' | WT. (LBS) | LIST | | | |
|------------|------------------|------|------------------|------|-----|------|--------|-------------------------|-------|-------|-------|------------|-----------|-------------|--------------|-------------|-------------|
| | MFG MODEL NUMBER | | | | | | | 0" | 1/4" | 1/2" | 3/4" | | | TEC | | EXP | |
| | 1 PH | 3 PH | 1 PH | 3 PH | | | | 1 PH | 3 PH | 1 PH | 3 PH | | | | | | |
| 12" | TXD12-1/4 | | TXD12-1/4-3 | | 1/4 | 1725 | 4 | 1180 | 520 | ---- | ---- | 77 | 40 | 2137 | 2115 | 2659 | 2748 |
| | TXD12-1/2 | | TXD12-1/2-3 | | 1/2 | 3450 | 4 | 1875 | 1400 | 1250 | 1100 | 82 | 45 | 2198 | 2190 | 2969 | 3303 |
| | TXD12-3/4 | | TXD12-3/4-3 | | 3/4 | 3450 | 6 | 2044 | 1920 | 1650 | 1500 | 83 | 45 | 2279 | 2279 | 3170 | 3414 |
| 18" | TXD18-1/4 | | TXD18-1/4-3 | | 1/4 | 1725 | 4 | 3450 | 2500 | ---- | ---- | 74 | 55 | 2525 | 2501 | 3042 | 3130 |
| | TXD18-1/3 | | TXD18-1/3-3 | | 1/3 | 1725 | 6 | 3375 | 2600 | 1400 | ---- | 75 | 65 | 2649 | 2671 | 3324 | 3511 |
| | TXD18-1/2 | | TXD18-1/2-3 | | 1/2 | 1725 | 6 | 4150 | 3150 | 1700 | ---- | 77 | 65 | 2753 | 2768 | 3556 | 3474 |
| | TXD18-1 | | TXD18-1-3 | | 1 | 1725 | 6 | 4600 | 4080 | 3000 | 2100 | 80 | 70 | 3104 | 2953 | 3873 | 3940 |
| 24" | TXD24-1/4 | | TXD24-1/4-3 | | 1/4 | 1725 | 2 | 5200 | 2820 | ---- | ---- | 80 | 95 | 2768 | 2753 | 3289 | 3309 |
| | TXD24-1/3 | | TXD24-1/3-3 | | 1/3 | 1140 | 6 | 4975 | 4250 | 2850 | ---- | 74 | 110 | 3332 | 3385 | 4545 | 4519 |
| | TXD24-1/2 | | TXD24-1/2-3 | | 1/2 | 1725 | 4 | 6510 | 5200 | 3100 | 1800 | 80 | 115 | 3060 | 3073 | 3860 | 3777 |
| | TXD24-3/4 | | TXD24-3/4-3 | | 3/4 | 1140 | 6 | 6900 | 6265 | 3300 | ---- | 74 | 125 | 4131 | 3675 | 4787 | 4636 |
| | TXD24-1 | | TXD24-1-3 | | 1 | 1725 | 6 | 7425 | 6350 | 5000 | 3300 | 82 | 120 | 3390 | 3236 | 4163 | 4232 |
| | TXD24-2 | | TXD24-2-3 | | 2 | 1725 | 6 | 9525 | 8810 | 7980 | 6960 | 84 | 120 | 4104 | 3495 | 5718 | 4643 |
| | ----- | | TXD24-3-3 | | 3 | 1725 | 6 | 10500 | 9500 | 8700 | 7800 | 86 | 130 | ---- | 3799 | ---- | 5023 |
| 27" | TXD27-1/2 | | TXD27-1/2-3 | | 1/2 | 1725 | 4 | 7550 | 6000 | 4000 | 2000 | 86 | 125 | 3341 | 3347 | 4131 | 4050 |
| | TXD27-1 | | TXD27-1-3 | | 1 | 1725 | 4 | 9600 | 8400 | 7050 | 4800 | 86 | 155 | 3619 | 3474 | 4392 | 4459 |
| | TXD27-2 | | TXD27-2-3 | | 2 | 1725 | 6 | 11500 | 10700 | 9300 | 8000 | 86 | 165 | 4414 | 3807 | 6029 | 4956 |
| 30" | TXD30-1/2 | | TXD30-1/2-3 | | 1/2 | 1725 | 4 | 8980 | 6300 | 4350 | 2300 | 86 | 130 | 3474 | 3488 | 4276 | 4193 |
| | TXD30-3/4 | | TXD30-3/4-3 | | 3/4 | 1140 | 6 | 10440 | 8750 | 6000 | ---- | 80 | 150 | 4669 | 4207 | 5327 | 5191 |
| | TXD30-2 | | TXD30-2-3 | | 2 | 1725 | 6 | 12000 | 10450 | 8700 | 6000 | 89 | 155 | 4541 | 3932 | 6157 | 5080 |
| | ----- | | TXD30-3-3 | | 3 | 1725 | 6 | 16000 | 14700 | 12900 | 10200 | 89 | 175 | ---- | 4111 | ---- | 5341 |
| 34" | TXD34-1 1/2 | | TXD34-1 1/2-3 | | 1.5 | 1725 | 4 | 13350 | 10000 | 7300 | ---- | 88 | 175 | 4669 | 4474 | 6787 | 5618 |
| | TXD34-2 | | TXD34-2-3 | | 2 | 1725 | 4 | 14850 | 12100 | 8800 | 4000 | 89 | 200 | 5169 | 4563 | 6787 | 5714 |
| | ----- | | TXD34-3-3 | | 3 | 1140 | 3 | 19300 | 17230 | 14800 | 11614 | 86 | 250 | ---- | 5910 | ---- | 7462 |
| | ----- | | TXD34-5-3 | | 5 | 1725 | 6 | 21000 | 18900 | 17500 | 14850 | 91 | 220 | ---- | 4858 | ---- | 6211 |
| 36" | TXD36-2 | | TXD36-2-3 | | 2 | 1140 | 6 | 17620 | 15200 | 12300 | 8500 | 84 | 210 | ---- | 5067 | ---- | 6389 |
| | ----- | | TXD36-3-3 | | 3 | 1725 | 4 | 18500 | 15700 | 13900 | 11500 | 89 | 230 | ---- | 5640 | ---- | 7187 |
| 42" | ----- | | TXD42-1-3 | | 1 | 870 | 4 | 15800 | 13480 | 5800 | 900 | 81 | 270 | ---- | 6128 | ---- | ---- |
| | TXD42-2 | | TXD42-2-3 | | 2 | 1140 | 4 | 17964 | 15326 | 12351 | 7600 | 87 | 260 | ---- | 5772 | ---- | 7083 |
| | ----- | | TXD42-3-3 | | 3 | 1140 | 4 | 24500 | 23000 | 19650 | 14000 | 87 | 260 | ---- | 6467 | ---- | 8019 |
| | ----- | | TXD42-5-3 | | 5 | 1140 | 4 | 28970 | 26840 | 24200 | 19500 | 87 | 300 | ---- | 6706 | ---- | 8924 |
| 48" | ----- | | TXD48-3-3 | | 3 | 1140 | 4 | 28600 | 24400 | 20000 | 15900 | 94 | 290 | ---- | 8064 | ---- | 9613 |
| | ----- | | TXD48-5-3 | | 5 | 870 | 4 | 33000 | 29750 | 25300 | 18000 | 86 | 500 | ---- | 10252 | ---- | ---- |

Duct Fan Guards

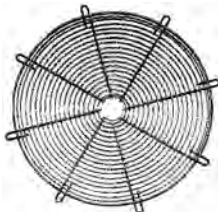

Features

- Enamel finish
- Can be used as front or rear guards. (Rear guard for TXD models must be ordered with fan)

⚠ WARNING: This product can expose you to chemicals including nickel which is known to the State of California to cause cancer, and chromium, which is known to the State of California to cause birth defects and/or reproductive harm. For more information go to www.P65Warnings.ca.gov.

Standard Models

| FAN SIZE | MFG MODEL | LIST | FAN SIZE | MFG MODEL | LIST |
|----------|-----------|------------|----------|-----------|------------|
| 12" | TXG-12 | 183 | 30" | TXG-30 | 249 |
| 15" | TXG-15 | 183 | 34" | TXG-34 | 317 |
| 18" | TXG-18 | 183 | 36" | TXG-36 | 328 |
| 24" | TXG-24 | 200 | 42" | TXG-42 | 360 |
| 27" | TXG-27 | 249 | 48" | TXG-48 | 469 |

Note: Products listed in this section are custom built and subject to 100% cancellation/restocking charges

Tubeaxial Belt Drive Duct Fans

Features

- Eliminates fumes and vapors from paint spray booths and other hazardous areas
- Totally enclosed and explosion proof motors
- 1-Phase motors are field convertible 115V/230V
- 3-Phase motors are field convertible 230V/460V
- Motors are set to lower voltage at the factory unless a request is made at time of order to set them to the higher voltage
- Explosion proof motors are Class 1, Div 1, Group D and Class 2, Div 1, Groups F & G
- Recommended for most paint spray applications because motor is out of air
- 14 gauge steel drum including mounting flanges at each end
- Completely enclosed belt and ball bearing housing
- Adjustable motor base for proper belt tension
- Rugged cast aluminum blade, non-sparking
- Fan can be mounted to operate in any position
- 1 year limited warranty

⚠ WARNING: This product can expose you to chemicals including nickel which is known to the State of California to cause cancer, and chromium, which is known to the State of California to cause birth defects and/or reproductive harm. For more information go to www.P65Warnings.ca.gov.



Options

- Companion flanges
- Protective coating
- Access doors
- Belt guards
- Motor covers
- Fan guards

Standard Models

| BLADE SIZE | 1-PHASE 115/230V-60Hz | 3-PHASE 230/460V-60Hz | HP | RPM | BLADES | C.F.M - STATIC PRESSURE | | | | Db's @10' | WT (LBS) | LIST | | | |
|------------|--------------------------|--------------------------|-----|------|--------|-------------------------|-------|-------|-------|--------------|-------------|------|-------|-------|-------|
| | | | | | | MFG MODEL NUMBER | | | | | | TEC | | EXP | |
| | | | | | | 0" | 1/4" | 1/2" | 3/4" | | | 1 PH | 3 PH | 1 PH | 3 PH |
| 12" | TXB12-1/4 | TXB12-1/4-3 | 1/4 | 2625 | 4 | 1444 | 1033 | 380 | ---- | 77 | 62 | 2881 | 2865 | 3423 | 3512 |
| | TXB12-1/3 | TXB12-1/3-3 | 1/3 | 2875 | 4 | 1586 | 1135 | 415 | ---- | 78 | 65 | 2939 | 2970 | 3645 | 3830 |
| | TXB12-1/2 | TXB12-1/2-3 | 1/2 | 3450 | 4 | 1875 | 1400 | 1250 | 1100 | 83 | 65 | 2939 | 2939 | 3621 | 3928 |
| | TXB12-3/4 | TXB12-3/4-3 | 3/4 | 3450 | 6 | 2044 | 1920 | 1650 | 1500 | 83 | 67 | 3200 | 3200 | 3868 | 4150 |
| 15" | TXB15-1/4 | TXB15-1/4-3 | 1/4 | 2000 | 6 | 2600 | 1700 | | ---- | 77 | 67 | 3171 | 3156 | 3710 | 3800 |
| | TXB15-1/3 | TXB15-1/3-3 | 1/3 | 2200 | 6 | 2950 | 2100 | 1000 | ---- | 78 | 69 | 3266 | 3291 | 3965 | 4150 |
| | TXB15-1/2 | TXB15-1/2-3 | 1/2 | 1890 | 6 | 3350 | 2650 | 1500 | ---- | 76 | 75 | 3363 | 3378 | 4194 | 4106 |
| | TXB15-3/4 | TXB15-3/4-3 | 3/4 | 2200 | 6 | 3900 | 3400 | 2700 | 1150 | 78 | 85 | 3659 | 3467 | 4491 | 4283 |
| 18" | TXB18-1/4 | TXB18-1/4-3 | 1/4 | 1600 | 6 | 3050 | 2000 | | ---- | 76 | 80 | 3348 | 3334 | 3889 | 3978 |
| | TXB18-1/3 | TXB18-1/3-3 | 1/3 | 1725 | 6 | 3375 | 2600 | 1400 | ---- | 77 | 85 | 3386 | 3437 | 4113 | 4299 |
| | TXB18-1/2 | TXB18-1/2-3 | 1/2 | 1890 | 6 | 3850 | 3100 | 2000 | ---- | 78 | 95 | 3512 | 3527 | 4343 | 4254 |
| | TXB18-1 | TXB18-1-3 | 1 | 1725 | 6 | 4600 | 4080 | 3000 | 2100 | 77 | 105 | 4007 | 3822 | 4770 | 4847 |
| 24" | TXB18-1 1/2 | TXB18-1 1/2-3 | 1.5 | 1990 | 6 | 5350 | 4830 | 3950 | 3000 | 80 | 105 | 4194 | 3999 | 6386 | 5183 |
| | TXB24-1/2 | TXB24-1/2-3 | 1/2 | 1298 | 6 | 5643 | 4826 | 3500 | ---- | 78 | 120 | 3809 | 3822 | 4637 | 4548 |
| | TXB24-3/4 | TXB24-3/4-3 | 3/4 | 1600 | 6 | 6906 | 5900 | 4650 | 2750 | 80 | 130 | 4159 | 3965 | 4986 | 4780 |
| | TXB24-1 | TXB24-1-3 | 1 | 1725 | 6 | 7425 | 6350 | 5000 | 3300 | 84 | 140 | 4194 | 4031 | 4986 | 5063 |
| | TXB24-1 1/2 | TXB24-1 1/2-3 | 1.5 | 1540 | 6 | 8200 | 7650 | 6850 | 5500 | 81 | 145 | 5098 | 4905 | 7280 | 6085 |
| | TXB24-2 | TXB24-2-3 | 2 | 1600 | 6 | 9760 | 8830 | 8090 | 7000 | 82 | 170 | 5797 | 5173 | 7456 | 6351 |
| 27" | ----- | TXB24-3-3 | 3 | 1725 | 6 | 10500 | 9500 | 8700 | 7800 | 86 | 190 | ---- | 5335 | ---- | 6607 |
| | TXB27-3/4 | TXB27-3/4-3 | 3/4 | 1250 | 6 | 8330 | 7550 | 6500 | 4650 | 78 | 150 | 5093 | 4891 | 5914 | 5715 |
| | TXB27-1 | TXB27-1-3 | 1 | 1400 | 6 | 9400 | 8480 | 7300 | 5200 | 82 | 155 | 5122 | 4964 | 5914 | 5982 |
| | TXB27-1 1/2 | TXB27-1 1/2-3 | 1.5 | 1600 | 6 | 10700 | 9700 | 8375 | 6000 | 84 | 170 | 5354 | 5158 | 7532 | 6328 |
| 30" | TXB27-2 | TXB27-2-3 | 2 | 1350 | 6 | 11500 | 10700 | 9300 | 8000 | 81 | 210 | 5968 | 5342 | 7637 | 6531 |
| | TXB30-1/2 | TXB30-1/2-3 | 1/2 | 1140 | 4 | 8900 | 6660 | 2300 | ---- | 79 | 140 | 4814 | 4842 | 5647 | 5566 |
| | TXB30-1 | TXB30-1-3 | 1 | 1298 | 6 | 9867 | 7980 | 4120 | ---- | 82 | 150 | 5342 | 5188 | 6136 | 6213 |
| | TXB30-1 1/2 | TXB30-1 1/2-3 | 1.5 | 1035 | 6 | 11100 | 9700 | 7500 | 3500 | 78 | 165 | 5574 | 5379 | 7756 | 6561 |
| | TXB30-2 | TXB30-2-3 | 2 | 1176 | 6 | 12100 | 11000 | 9322 | 6700 | 81 | 215 | 6099 | 5477 | 7769 | 6664 |
| | ----- | TXB30-3-3 | 3 | 1350 | 6 | 13480 | 12498 | 11465 | 10380 | 84 | 215 | ---- | 5841 | ---- | 7101 |
| 34" | ----- | TXB30-5-3 | 5 | 1650 | 6 | 16440 | 15242 | 13982 | 12659 | 88 | 230 | ---- | 5907 | ---- | 7289 |
| | TXB34-1 1/2 | TXB34-1 1/2-3 | 1.5 | 1170 | 6 | 13695 | 11100 | 6000 | 1015 | 82 | 190 | 6442 | 6252 | 8625 | 7422 |
| | TXB34-2 | TXB34-2-3 | 2 | 1027 | 6 | 14657 | 12590 | 10000 | 8000 | 81 | 240 | 7176 | 6553 | 8839 | 7739 |
| | ----- | TXB34-3-3 | 3 | 1175 | 6 | 17580 | 15896 | 14095 | 12000 | 85 | 260 | ---- | 6724 | ---- | 7985 |
| | ----- | TXB34-5-3 | 5 | 1416 | 6 | 20500 | 19000 | 17500 | 16000 | 88 | 305 | ---- | 6768 | ---- | 8163 |
| 42" | TXB42-1 1/2 | TXB42-1 1/2-3 | 1.5 | 750 | 4 | 18960 | 14662 | 7200 | ---- | 78 | 250 | 7637 | 7673 | 10049 | 8846 |
| | TXB42-2 | TXB42-2-3 | 2 | 820 | 4 | 20700 | 17002 | 11400 | 4000 | 80 | 260 | 8175 | 7800 | 10094 | 8981 |
| | ----- | TXB42-3-3 | 3 | 890 | 4 | 23700 | 20200 | 16970 | 9950 | 82 | 260 | ---- | 7961 | ---- | 9222 |
| | ----- | TXB42-5-3 | 5 | 850 | 6 | 26900 | 24403 | 22250 | 18400 | 82 | 270 | ---- | 8378 | ---- | 9767 |
| 48" | ----- | TXB48-5-3 | 5 | 800 | 6 | 33000 | 29000 | 25600 | 20000 | 85 | 375 | ---- | 12419 | ---- | 13811 |
| | ----- | TXB48-7 1/2-3 | 7.5 | 900 | 6 | 37000 | 34500 | 31000 | 27000 | 87 | 520 | ---- | 13192 | ---- | 15532 |

| SIZE | HOUSING INNER DIMENSION | HOUSING OUTER DIMENSION | BOLT HOLE CENTERS | HOUSING DEPTH |
|------|-------------------------|-------------------------|-------------------|---------------|
| 12" | 12" | 14" | 13 1/8" | 12" |
| 15" | 15" | 17" | 16 1/8" | 12" |
| 18" | 18" | 20" | 19 1/8" | 12" |
| 24" | 24" | 27" | 25 3/4" | 12" & 16" |
| 27" | 27" | 30" | 28 3/4" | 16" |
| 30" | 30" | 33" | 31 3/4" | 16" |
| 34" | 34" | 37" | 35 3/4" | 16" |
| 42" | 42" | 45" | 43 3/16" | 18" |
| 48" | 48" | 51" | 49 3/8" | 24" |

Note: Products listed in this section are custom built and subject to 100% cancellation/restocking charges

Attic Fans

Power Attic Mount Dome Ventilator



WARNING: This product can expose you to chemicals including nickel which is known to the State of California to cause cancer, and chromium, which is known to the State of California to cause birth defects and/or reproductive harm. For more information go to www.P65Warnings.ca.gov.

Features

- 120V Motor / 1-Phase
- Automatic thermostat (60°-120°F)
- Insect and bird screen installed
- Black or brown painted finish or mill finish
- Made in U.S.A.

Note: Photograph is a representation of stocked models. Actual model may vary in appearance.

Standard Models

| MFG CATALOG NUMBER | MFG MODEL NUMBER | DOMES COLOR | SPEED | CFM .03 SP | VOLTS | HP | RPM | ATTIC SIZE / SQ. FT.* | WT. (LBS) | LIST |
|--------------------|-------------------|-------------|-------|------------|-------|------|------|-----------------------|-----------|------------|
| 08664202 | PDV-305-1MB-GY-G | Mill | 1 | 1000 | 120 | 1/12 | 1050 | Average/1600 | 19 | 228 |
| 08664302 | PDV-305-1MB-BR-G | Brown | 1 | 1000 | 120 | 1/12 | 1050 | Average/1600 | 19 | |
| 08664402 | PDV-305-1MB-BLK-G | Black | 1 | 1000 | 120 | 1/12 | 1050 | Average/1600 | 19 | |

*@ 4:12 Pitch Roof

Gable Exhaust Fan



Damper requires 16 1/2 x 16 1/2 opening



WARNING: This product can expose you to chemicals including nickel which is known to the State of California to cause cancer, and chromium, which is known to the State of California to cause birth defects and/or reproductive harm. For more information go to www.P65Warnings.ca.gov.

Features

- 120V motor / 1-Phase
- Automatic adjustable thermostat (60°-120°F)
- Partially assembled (mounting tabs must be assembled)
- 14" blade diameter
- 4 mounting tabs on 16" centers
- Made in U.S.A.

Standard Models

| MFG CATALOG NUMBER | MFG MODEL NUMBER | DESCRIPTION | CFM .03 SP | ATTIC SIZE/ SQ. FT.* | WT. (LBS) | LIST |
|--------------------|------------------|------------------------------------|------------|----------------------|-----------|------------|
| 08663702 | GV-405-2B-G | Gable Mount Ventilator | 1540 | Average/2400 | 13 | 177 |
| 08665202 | AGD-1416B-G | White Aluminum Damper for GV-405-2 | ---- | ---- | 3 | 103 |

*@ 4:12 Pitch Roof

Belt Drive Wholehouse Fans



WARNING: This product can expose you to chemicals including nickel which is known to the State of California to cause cancer, and chromium, which is known to the State of California to cause birth defects and/or reproductive harm. For more information go to www.P65Warnings.ca.gov.

Features

- 120V, 1-Phase, 2-Speed motors
- Shutters automatically open when fan is turned on and close tightly when fan is turned off
- Made in U.S.A.

Standard Models

| MFG CATALOG NUMBER | MFG MODEL NUMBER | SIZE | SPEED | MOTOR HP | CFM @ .1 IN. H2O PRESSURE DROP w/ SHUTTER | FAN SPEED RPM | FAN MOUNTING DIMENSIONS (IN) | | | EXHAUST SQ. FT. REQ'D | AMPS | WT. (LBS) | LIST |
|--------------------|------------------|------|-------|----------|---|---------------|------------------------------|------|------|-----------------------|---------|-----------|-------------|
| | | | | | | | A | B | C | | | | |
| 07936202 | BD24-2-WHS | 24" | 2 | 1/3 | 4500/2700 | 612/410 | 28 | 29.5 | 14.5 | 7 | 5.7/4.8 | 40 | 1033 |
| 07936302 | BD30-2-WHS | 30" | 2 | 1/3 | 7600/5800 | 520/350 | 34 | 35.5 | 14.5 | 9 | 6.9/5.5 | 50 | 1110 |
| 07936402 | BD36-2-WHS | 36" | 2 | 1/3 | 9675/6400 | 395/265 | 40 | 41.5 | 14.5 | 12 | 6.3/3.1 | 64 | 1220 |

Fan Dimensions

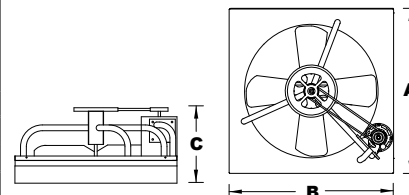

Ceiling Shutters

| MFG CATALOG NUMBER | MFG MODEL NUMBER | FIT HOLE SIZE (I.D.) | OUTSIDE SIZE (O.D.) | FAN SIZE | WT. (LBS) | LIST |
|--------------------|------------------|----------------------|---------------------|----------|-----------|------------|
| 07944802 | CS-10-W | 26X26 | 28X28 | 24" | 8 | 183 |
| 07944602 | CS-13-W | 32X34 | 34X36 | 30" | 10 | 191 |
| 07945302 | CS-14-W | 34X34 | 36X36 | 30" | 10 | 201 |
| 07944702 | CS-18-W | 32X43 | 34X45 | 36" | 11 | 217 |
| 07945202 | CS-19-W | 34X43 | 36X45 | 36" | 11 | 235 |

"Joist out style" (For replacement only)

Control Options

| MFG CATALOG NUMBER | MFG MODEL NUMBER | DESCRIPTION | WT. (LBS) | LIST |
|--------------------|------------------|---|-----------|-----------|
| 07927002 | 2-SW | 2 Speed wall switch & plate | 1 | 51 |
| 05000802 | 1A22-7 | SP Close on rise (Attic Thermostat) (80°-130°F) | 1 | 64 |

WARNING: This product can expose you to chemicals including nickel which is known to the State of California to cause cancer, and chromium, which is known to the State of California to cause birth defects and/or reproductive harm. For more information go to www.P65Warnings.ca.gov.

Loading Dock Lights - Shipped in 1-Carton

Light Head Features

- Chip resistant safety yellow & black powder coating finish for high visibility and durability
- 5' long 18/3 SJT, 120V cordset with NEMA 15-5 grounded plug
- On/Off switch & wire guard included on each light head
- 1-1/2" square, 11-gauge, steel tubing
- 3" x 5" x 3/16" mounting plate attached with (4) 3/8" bolts (not supplied)
- VA & DKLED models have vertical adjustment bracket allowing outer arm to adjust from 300° horizontally and 210° vertically
- All light heads will swivel 300°
- VA Models include an embedded electrical outlet for direct plug connection from the light head fixture and shipped fully-assembled
- DKLED units contain a die-cast aluminum light head with adjustable knobs, built-in on/off switch, and maintains an IP65 rating suitable for wet locations
- DKLED units use a 20° custom beam angle and 12 individual high-intensity LED emitters generating a neutral white color; with a CCT measuring 4,000K DKLED units provide a minimum life of 50,000 hours and offers a 5-year warranty, including CE & RoHS Certificates
- Designed for loading dock and work station environments
- ETL C/US Listed for indoor applications only, except QH models are semi-protected outdoor and DKLED models have IP65 rating suitable for wet location areas



DKL-40VA-A

Flexible elastomer arm moves when hit and then returns light to original position



DKL-25-FLX

LED 30-Watt



DKLED-40-30W



WARNING: This product can expose you to chemicals including nickel which is known to the State of California to cause cancer, and chromium, which is known to the State of California to cause birth defects and/or reproductive harm. For more information go to www.P65Warnings.ca.gov.

Standard Models (120V)

| MFG CATALOG NUMBER | MFG MODEL NUMBER | ARM LENGTH | # OF ARMS | MAX WATTS | WT. (LBS) | LIST |
|---|------------------|------------|-----------|-------------|-----------|------------|
| NO BULB | | | | | | |
| 04466502 | DKL-40VA-A | 40" | 2 | Maximum 300 | 14 | 259 |
| 04466602 | DKL-60VA-A | 60" | 2 | | 17 | 311 |
| 03854001 | DKL-25-FLX | 25" | 1 | | 17 | 274 |
| LED - 3,300 Lumens, 4,000K CCT, 50,000-hour Avg. Bulb Life | | | | | | |
| 04922802 | DKLED-40-30W | 40" | 2 | 30 | 13 | 400 |
| 04922902 | DKLED-42-30W | 42" | 3 | | 14 | 421 |



Spot Task Lighting
When & where you need it!



DKLED-42-30W



Loading Dock Lights - Modular (shipped in multiple cartons)

Modular Lights



DKL-INC



DKL-LED37



DKL-QH



DKL-LED-30W-SP



DKLED-30W-WP

Features

- 14" long, 18/3 conductor cord plugs into electrical junction box on arm
- On/Off switch & wire guard included with each light head
- Bulb included with all light heads except DKL-INC
- Imported to TPI specifications.
- DKL-LED-37 is compliant with ROHS 2 Directive (2011/65/EU), that of which includes the application exemptions outlined in Annex III of the directive.



WARNING: This product can expose you to chemicals including nickel which is known to the State of California to cause cancer, and chromium, which is known to the State of California to cause birth defects and/or reproductive harm. For more information go to www.P65Warnings.ca.gov.

Standard Models

| MFG CATALOG NUMBER | MFG MODEL NUMBER | LIGHT HEAD TYPE | MAX WATTS | MAX LUMENS | AVE. BULB LIFE (HRS) | WT. (LBS) | LIST |
|--------------------|------------------|---------------------------|-----------|------------|----------------------|-----------|------------|
| 04465602 | DKL-INC | No Bulb Included | 300 | 3,700 | 2,000 | 5 | 106 |
| 04465702 | DKL-QH | Quartz Halogen | 500 | 11,000 | 2,000 | 6 | 159 |
| 04881302 | DKL-LED-37 | LED | 37 | 2,373 | >30,000 | 5 | 424 |
| 04923002 | DKLED-30W-WP | LED w/ Pin Connector Plug | 30 | 3,300 | 50,000 | 7 | 302 |
| 04923102 | DKLED-30W-SP | LED w/ Grounded Plug | 30 | 3,300 | 50,000 | 7 | 302 |

Mounting Arms



DKL-40VA-ARM



60-LDA



24-LDA



The outer arm on 40VA & 60VA arms will swing 300° in horizontal plane & 210° in vertical plane

Features

- 1 1/2" square, 11 gauge, steel tubing
- 3" x 5" x 3/16" mounting plate attaches with (4) 3/8" bolts
- 5' long, 18/3 SJTW conductor cord and NEMA 5-15 grounded plug
- Made in U.S.A.

WARNING: This product can expose you to chemicals including nickel which is known to the State of California to cause cancer, and chromium, which is known to the State of California to cause birth defects and/or reproductive harm. For more information go to www.P65Warnings.ca.gov.

Standard Models

| MFG CATALOG NUMBER | MFG MODEL NUMBER | ARM LENGTH | TOTAL # OF ARMS | WT. (LBS) | LIST |
|--------------------|------------------|------------|-----------------|-----------|------------|
| 04465402 | DKL-40VA-ARM | 40" | 2 | 18 | 161 |
| 04465502 | DKL-60VA-ARM | 60" | 2 | 24 | 204 |
| 04465302 | 24-LDA | 24" | 1 | 11 | 126 |
| 04466102 | 40-LDA** | 40" | 3 | 18 | 217 |
| 04466202 | 60-LDA** | 60" | 3 | 24 | 252 |

**Indicates heavy duty dock arms (Horizontal swing only, no vertical movement)

Loading Dock Arm Fan



Features

- 18" high velocity circulator, with 3 speed, 1/8 HP, 115V, 1 phase permanently lubricated, totally enclosed, PSC motor
- Modular fan plugs into electrical outlet on arm
- Coated steel guards and aluminum blades
- Imported to TPI specifications

WARNING: This product can expose you to chemicals including nickel which is known to the State of California to cause cancer, and chromium, which is known to the State of California to cause birth defects and/or reproductive harm. For more information go to www.P65Warnings.ca.gov.

Standard Models

| MFG CATALOG NUMBER | MFG MODEL NUMBER | CFM | | | VELOCITY PROFILE MAX. CFM | AMPS HIGH | WT. (LBS) | LIST |
|--------------------|------------------|------|------|------|---------------------------|-----------|-----------|------------|
| | | HIGH | MED | LOW | | | | |
| 07971802 | LDF-18-TE | 1800 | 1500 | 1300 | 2900 | 2.2 | 20 | 257 |

Note: Must be used with LDA (Heavy Duty) mounting arms

Machine Tool Lights

Water Resistant Fluorescent or LED Tube Lights



23-TLP-24VDC

⚠ WARNING: This product can expose you to chemicals including nickel which is known to the State of California to cause cancer, and chromium, which is known to the State of California to cause birth defects and/or reproductive harm. For more information go to www.P65Warnings.ca.gov.



29-LED



21-LED

Features

- All tube lights come standard with a durable, lightweight, economical, shatter-resistant polycarbonate tube housing
- Stainless steel mounting brackets (2), fasteners and threaded conduit fitting included with all models
- LEDTLP Models are ETL C/US Listed for NEMA Type 13 applications - oil / water / coolant spray areas (not submersible) and dusty atmospheres
- LED Models operate at 120V and include an 8' long, 18/3 SJTOW cord with NEMA 5-15 grounded plug
- LED Models comply with part-15 of the FCC rule
- Model 21-LEDTLP-120-16 includes an aluminum enclosure with on/off power switch
- Model 21-LED generates 100-watts of an incandescent light output equivalent, but only consumes 16-watts of power; Model 29-LED generates 150-watts, using only 26-watts of power.
- 23-TLP-24VDC uses a fluorescent bulb and operates at low voltage of 24V DC, includes on board ballast and 2' long lead wires for direct connection; unit is NOT ETL Listed
- All units are made in the U.S.A.

Standard Models

| MFG CATALOG NUMBER | MFG MODEL NUMBER | DESCRIPTION | WATTS | VOLTS | LUMENS | OVERALL LENGTH | TUBE MATERIAL | BALLAST INCLUDED | WT. (LBS) | LIST |
|--------------------|------------------|--|-------|-------|--------|----------------|---------------|------------------|-----------|------------|
| 04829302 | 23-TLP-24VDC | Fluorescent, w/wire leads | 18 | 24VDC | 1250 | 23" | Polycarbonate | Yes | 6 | 528 |
| 04891802 | 21-LEDTLP-120-16 | LED, on/off switch enclosure & cordset | 16 | 120V | 1200 | 21" | Polycarbonate | No | 4 | 604 |
| 04891902 | 29-LEDTLP-120-26 | LED w/cordset | 26 | 120V | 2800 | 29" | Polycarbonate | No | 3 | 673 |

Accessories - Replacement Lamps

| MFG CATALOG NUMBER | MFG MODEL NUMBER | DESCRIPTION | USED WITH | WT. (LBS) | LIST |
|--------------------|------------------|---|--------------|-----------|-----------|
| 3103300 | TL-RB-18 | Fluorescent Replacement Bulb, 18W, PL-L | 23-TLP-24VDC | 1 | 80 |

Commercial Duty Portable Utility Lights

CL 300 (Clamp on Model)

Features



⚠ WARNING: This product can expose you to chemicals including nickel which is known to the State of California to cause cancer, and chromium, which is known to the State of California to cause birth defects and/or reproductive harm. For more information go to www.P65Warnings.ca.gov.

- Ceramic socket will accept incandescent bulbs A-19, R-40 or PAR bulbs up to 300 Watt. Fixture will also accept infrared heat lamps up to 250 Watts
- 11-watt LED bulb included
- 8' long - 18/3 SPT cordset with NEMA 5-15 plug
- Imported to TPI specifications.

| MFG CATALOG NUMBER | MFG MODEL NUMBER | BASE TYPE | DESCRIPTION | MAX. WATTS | VOLTS | MAX LUMENS | AVE. BULB LIFE HOURS | WT. (LBS) | LIST |
|--------------------|------------------|-----------|--------------|------------|-------|------------|----------------------|-----------|-----------|
| 02804900 | CL-300 | CLIP-ON | 11-Watt, LED | 300 | 120 | 800 | 25,000 | 3 | 96 |

CL-300 is shipped in ONE carton. LED bulb included

Product Index Listing

46

INDEX

| MODEL | PAGE | MODEL | PAGE | MODEL | PAGE | MODEL | PAGE |
|------------------|------|---------------|------|-----------|--------|--------------|--------|
| 1A22-7 | 42 | CACU 24-PO | 8 | CE 24-DV | 26 | CESM-30 | 33 |
| 2-SW | 42 | CACU 24-W | 8 | CE 30-D | 25 | CESM-36 | 33 |
| 21-LEDTLP-120-16 | 45 | CACU 24-WO | 8 | CE 30-DS | 24 | CESM-42 | 33 |
| 29-LEDTLP-120-26 | 45 | CACU 30-P | 8 | CE 30-DV | 26 | CESM-48 | 33 |
| 23-TLP-24VDC | 45 | CACU 30-P-HD | 8 | CE-24B | 27 | CESM-60 | 33 |
| 24-LDA | 44 | CACU 30-PO | 8 | CE-24B-3 | 27 | CF-12 | 20 |
| 24-LDF-TE | 21 | CACU 30-PO-HD | 8 | CE-30B | 27 | CF-18 | 20 |
| 40-LDA | 44 | CACU 30-W | 8 | CE-30B-3 | 27 | CF-20 | 20 |
| 40-LDF-TE | 21 | CACU 30-WO | 8 | CE-36B | 27 | CL-300 | 45 |
| 60-LDA | 44 | CAS - 18 | 16 | CE-36B-3 | 27 | CPB 30-D | 9 |
| 60-LDF-TE | 21 | CAS - 48 | 16 | CE-42B | 27 | CPB 36-B | 9 |
| ACH 20 | 3 | CBT-24B | 31 | CE-42-B-3 | 27 | CPB 36-D | 9 |
| ACH 20-O | 3 | CBT-24B-3 | 32 | CE-48B | 27 | CPB 42-B | 9 |
| ACH 24 | 3 | CBT-30B | 32 | CE-48-B-3 | 27 | CPB 48-B | 9 |
| ACH 24-EX1 | 5 | CBT-30B-3 | 32 | CEFP-12 | 35 | CPBS 24-DHV | 9 |
| ACH 24-EX3 | 5 | CBT-36B | 32 | CEFP-16 | 35 | CPBS 30-D | 9 |
| ACH 24-O | 3 | CBT-36B-3 | 32 | CEFP-18 | 35 | CS-10-W | 42 |
| ACH 24-TE3 | 5 | CBT-42B | 32 | CEFP-20 | 35 | CS-13-W | 42 |
| ACH 30-TE3 | 5 | CBT-42B-3 | 32 | CEFP-24 | 35 | CS-14-W | 42 |
| ACH 30 | 3 | CBT-48B | 32 | CEFP-30 | 35 | CS-18-W | 42 |
| ACH 30-EX1 | 5 | CBT-48B-3 | 32 | CEFP-36 | 35 | CS-19-W | 42 |
| ACH 30-EX3 | 5 | CD-18 | 36 | CEFP-42 | 35 | DKL-25-FLX | 43 |
| ACH 30-O | 3 | CD-24 | 36 | CEFP-48 | 35 | DKL-40VA-A | 43 |
| ACM-C | 6 | CD-30 | 36 | CEFP-60 | 35 | DKL-40VA-ARM | 44 |
| ACM-I | 6 | CD-36 | 36 | CES 12-HD | 33 | DKL-60VA-A | 43 |
| ACM-P | 6 | CD-42 | 36 | CES 16-HD | 33 | DKL-60VA-ARM | 44 |
| ACM-PM | 6 | CD-48 | 36 | CES 18-HD | 33 | DKL-INC | 21, 44 |
| ACM-S | 6 | CD-54 | 36 | CES 20-HD | 33 | DKLED-30W-WP | 44 |
| ACM-W | 6 | CD-60 | 36 | CES 24-HD | 33 | DKLED-30W-SP | 44 |
| ACM-WK | 6 | CE 10-D | 25 | CES 30-HD | 33 | DKLED-40-30W | 43 |
| ACU 20-P | 4 | CE 10-DS | 24 | CES 36-HD | 33 | DKLED-42-30W | 43 |
| ACU 20-PO | 4 | CE 10-DV | 26 | CES 42-HD | 33 | DKL-LED-37 | 44 |
| ACU 20-W | 4 | CE 12-D | 25 | CES 48-HD | 33 | DKL-QH | 21, 44 |
| ACU 20-WO | 4 | CE 12-DS | 24 | CES 54-HD | 33 | DMKP1 | 35 |
| ACU 24-P | 4 | CE 12-DV | 26 | CES 60-HD | 34 | DMKP2 | 36 |
| ACU 24-PO | 4 | CE 14-D | 26 | CES-10G | 25, 26 | DR36 | 24 |
| ACU 24-W | 4 | CE 14-DS | 24 | CES-12G | 25, 26 | E-56CF | 23 |
| ACU 24-WO | 4 | CE 14-DV | 26 | CES-14G | 25, 26 | E-60CF | 23 |
| ACU 30-P | 4 | CE 16-D | 25 | CES-16G | 25, 26 | E-60CFC | 23 |
| ACU 30-PO | 4 | CE 16-DS | 24 | CES-18G | 25, 26 | EHB24-1 | 31 |
| ACU 30-W | 4 | CE 16-DV | 26 | CES-20G | 25, 26 | EHB24-1-3 | 31 |
| ACU 30-WO | 4 | CE 18-D | 25 | CES-24 | 27 | EHB24-1/2 | 31 |
| AGD-1416B-G | 42 | CE 18-DS | 24 | CES-24G | 25, 26 | EHB24-1/2-3 | 31 |
| BD24-2-WHS | 42 | CE 18-DV | 26 | CES-30 | 27 | EHB24-1/4 | 31 |
| BD30-2-WHS | 42 | CE 20-D | 25 | CES-30G | 25, 26 | EHB24-1/4-3 | 31 |
| BD36-2-WHS | 42 | CE 20-DS | 24 | CES-36 | 27 | EHB24-3/4 | 31 |
| CACU 20-P | 8 | CE 20-DV | 26 | CES-42 | 27 | EHB24-3/4-3 | 31 |
| CACU 20-W | 8 | CE 24-D | 25 | CES-48 | 27 | EHB30-1 | 31 |
| CACU 24-P | 8 | CE 24-DS | 24 | CESM-24 | 33 | EHB30-1 1/2 | 31 |

| MODEL | PAGE | MODEL | PAGE | MODEL | PAGE | MODEL | PAGE |
|---------------|------|---------------|------|---------------|------|---------------|------|
| EHB30-1 1/2-3 | 31 | EHB60-1 1/2-3 | 31 | EHD36-5-3 | 30 | HDM-C | 6 |
| EHB30-1-3 | 31 | EHB60-1-3 | 31 | EHD42-1-3 | 30 | HDM-I | 6 |
| EHB30-1/2 | 31 | EHB60-2 | 31 | EHD42-2 | 30 | HDM-P | 6 |
| EHB30-1/2-3 | 31 | EHB60-2-3 | 31 | EHD42-2-3 | 30 | HDM-W | 6 |
| EHB30-1/3 | 31 | EHB60-3-3 | 31 | EHD42-3-3 | 30 | HV-1 | 15 |
| EHB30-1/3-3 | 31 | EHB60-5-3 | 31 | EHD42-5-3 | 30 | HV-2 | 15 |
| EHB30-1/4 | 31 | EHD12-1/4 | 30 | EHD48-3-3 | 30 | HV-3 | 15 |
| EHB30-1/4-3 | 31 | EHD12-1/4-3 | 30 | EHD48-5-3 | 30 | HV-4-18 | 15 |
| EHB30-3/4 | 31 | EHD16-1/4 | 30 | EHD60-10-3 | 30 | HV-4-24 | 15 |
| EHB30-3/4-3 | 31 | EHD16-1/4-3 | 30 | EHD60-3-3 | 30 | HV-4-30 | 15 |
| EHB36-1 | 31 | EHD18-1/2 | 30 | EHD60-5-5 | 30 | HV-5-18 | 15 |
| EHB36-1 1/2 | 31 | EHD18-1/2-3 | 30 | EHD60-7 1/2-3 | 30 | HV-5-24 | 15 |
| EHB36-1 1/2-3 | 31 | EHD18-1/3 | 30 | EMF-12 | 34 | HV-5-30 | 15 |
| EHB36-1-3 | 31 | EHD18-1/3-3 | 30 | EMF-16 | 34 | HV-6-18 | 15 |
| EHB36-1/2 | 31 | EHD20-1 | 30 | EMF-20 | 34 | HV-6-24 | 15 |
| EHB36-1/2-3 | 31 | EHD20-1-3 | 30 | EMF-24 | 34 | HV-6-30 | 15 |
| EHB36-1/3 | 31 | EHD20-1/2 | 30 | EMF-30 | 34 | HV-7-DC-1 | 15 |
| EHB36-1/3-3 | 31 | EHD20-1/2-3 | 30 | EMF-36 | 34 | HV-7-DC-3 | 15 |
| EHB36-2 | 31 | EHD20-1/4 | 30 | EMF-42 | 34 | HV-8 | 15 |
| EHB36-2-3 | 31 | EHD20-1/4-3 | 30 | EMF-48 | 34 | HV18-120V | 15 |
| EHB36-3/4 | 31 | EHD24-1 | 30 | EMF-60 | 34 | HV18-208/240V | 15 |
| EHB36-3/4-3 | 31 | EHD24-1-3 | 30 | F-12-TE | 18 | HV18-277V | 15 |
| EHB42-1 | 31 | EHD24-1/2 | 30 | F-18-CR | 18 | HV18-480V | 15 |
| EHB42-1 1/2 | 31 | EHD24-1/2-3 | 30 | F-18-TE | 18 | HV24-120V | 15 |
| EHB42-1 1/2-3 | 31 | EHD24-1/3 | 30 | F-18H-CR | 18 | HV24-208/240V | 15 |
| EHB42-1-3 | 31 | EHD24-1/3-3 | 30 | F-18H-TE | 18 | HV24-277V | 15 |
| EHB42-1/2 | 31 | EHD24-1/4 | 30 | F-24-CR | 18 | HV24-480V | 15 |
| EHB42-1/2-3 | 31 | EHD24-1/4-3 | 30 | F-24-TE | 18 | HV30-120V | 15 |
| EHB42-1/3 | 31 | EHD24-2 | 30 | F-24-TE-HV | 18 | HV30-208/240V | 15 |
| EHB42-1/3-3 | 31 | EHD24-2-3 | 30 | F-24H-CR | 18 | HV30-277V | 15 |
| EHB42-2 | 31 | EHD24-3-3 | 30 | F-24H-TE | 18 | HV30-480V | 15 |
| EHB42-2-3 | 31 | EHD24-3/4 | 30 | FLS-18 | 35 | HV18-480V-3 | 15 |
| EHB42-3-3 | 31 | EHD24-3/4-3 | 30 | FLS-24 | 36 | HV24-480V-3 | 15 |
| EHB42-3/4 | 31 | EHD30-1 1/2 | 30 | FLS-30 | 36 | HV30-480V-3 | 15 |
| EHB42-3/4-3 | 31 | EHD30-1 1/2-3 | 30 | FLS-36 | 36 | IBG-12 | 34 |
| EHB48-1 | 31 | EHD30-1-3 | 30 | FLS-42 | 36 | IBG-16 | 34 |
| EHB48-1 1/2 | 31 | EHD30-1/2 | 30 | FLS-48 | 36 | IBG-18 | 34 |
| EHB48-1 1/2-3 | 31 | EHD30-1/2-3 | 30 | FLS-54 | 36 | IBG-20 | 34 |
| EHB48-1-3 | 31 | EHD30-1/3 | 30 | FLS-60 | 36 | IBG-24 | 34 |
| EHB48-1/2 | 31 | EHD30-1/3-3 | 30 | GV-405-2B-G | 42 | IBG-30 | 34 |
| EHB48-1/2-3 | 31 | EHD30-2 | 30 | HDH 24 | 2 | IBG-36 | 34 |
| EHB48-2 | 31 | EHD30-2-3 | 30 | HDH 24-G | 3 | IBG-42 | 34 |
| EHB48-2-3 | 31 | EHD30-3-3 | 30 | HDH 24-GJR | 3 | IBG-48 | 34 |
| EHB48-3-3 | 31 | EHD30-3/4 | 30 | HDH 24-JR | 2 | IBG-60 | 34 |
| EHB48-3/4 | 31 | EHD30-3/4-3 | 30 | HDH 30 | 2 | IE24-1 | 29 |
| EHB48-3/4-3 | 31 | EHD36-1 | 30 | HDH 30-G | 3 | IE24-1-3 | 29 |
| EHB48-5-3 | 31 | EHD36-1-3 | 30 | HDH 30-GJR | 3 | IE24-1/2 | 29 |
| EHB60-1 | 31 | EHD36-2-3 | 30 | HDH 30-JR | 2 | IE24-1/2-3 | 29 |
| EHB60-1 1/2 | 31 | EHD36-3-3 | 30 | HDH 36 | 3 | IE24-1/3 | 29 |

Product Index Listing

| MODEL | PAGE | MODEL | PAGE | MODEL | PAGE | MODEL | PAGE |
|--------------|------|---------------|--------|-------------------|--------|------------------|------|
| IE24-1/3-3 | 29 | IED16-1/3-3 | 28 | MCD36-5 | 16, 17 | PDV-305-1MB-BR-G | 42 |
| IE24-3/4 | 29 | IED18-1/2 | 28 | MCD42-2 | 16 | PDV-305-1MB-GY-G | 42 |
| IE24-3/4-3 | 29 | IED18-1/2-3 | 28 | MCD42-5 | 16 | PM-1 | 19 |
| IE30-1 | 29 | IED20-3/4 | 28 | MCD48-10 | 16 | PM-1.5 | 19 |
| IE30-1-3 | 29 | IED20-3/4-3 | 28 | MCD48-5 | 16 | PM-18C | 22 |
| IE30-1/2 | 29 | IED24-1 | 28 | MCD48-7 1/2 | 16 | PM-18FO | 22 |
| IE30-1/2-3 | 29 | IED24-1-3 | 28 | MCD60-10 | 16 | PM-18S | 22 |
| IE30-1/3 | 29 | IED30-1 | 28 | MCD60-15 | 16 | PM-2 | 19 |
| IE30-1/3-3 | 29 | IED30-1-3 | 28 | MCD60-3 | 16 | PM-2.5 | 19 |
| IE30-3/4 | 29 | IED36-1 1/2 | 28 | MCD60-5 | 16 | PM-3 | 19 |
| IE30-3/4-3 | 29 | IED36-1 1/2-3 | 28 | MCD60-7 1/2 | 16 | PM-18S | 22 |
| IE36-1 | 29 | IED42-2-3 | 28 | MK-1 | 33 | PM-18C | 22 |
| IE36-1 1/2 | 29 | IED48-3-3 | 28 | MK-2 | 33 | PM-18FO | 22 |
| IE36-1 1/2-3 | 29 | IHP 20-H-WD | 5 | MK-3 | 33 | QH-2 | 44 |
| IE36-1-3 | 29 | IHP 24-H | 3 | N-12 | 21 | RDS-18 | 36 |
| IE36-1/2 | 29 | IHP 24-H-277 | 5 | NK-PM18 | 22 | RDS-24 | 36 |
| IE36-1/2-3 | 29 | IHP 24-H-WD | 5 | ODF-12 | 20 | RDS-30 | 36 |
| IE36-1/3 | 29 | IHP 30-H | 3 | ODF-16 | 20 | RDS-36 | 36 |
| IE36-1/3-3 | 29 | IHP 30-H-277 | 5 | OSF-16 | 20 | RDS-42 | 36 |
| IE36-2 | 29 | IHP 30-H-WD | 5 | PBX 30-D | 10 | RDS-48 | 36 |
| IE36-2-3 | 29 | KBWC-110K | 23 | PBX 36-B | 11 | RDS-54 | 36 |
| IE36-3/4 | 29 | KBWC-15SK | 23 | PB 36-B-3 | 11 | RDS-60 | 36 |
| IE36-3/4-3 | 29 | LDF-18-TE | 21, 44 | PB 36-B-HL | 11 | RE24-1 | 37 |
| IE42-1 | 29 | MB 24-DF | 13 | PBX 36-D | 10 | RE24-1-3 | 37 |
| IE42-1 1/2 | 29 | MB 24-DY | 13 | PBX 42-B | 11 | RE24-1/2 | 37 |
| IE42-1 1/2-3 | 29 | MB 30-DF | 13 | PB 42-B-3 | 11 | RE24-1/2-3 | 37 |
| IE42-1-3 | 29 | MB 30-DY | 13 | PB 42-B-HL | 11 | RE24-1/4 | 37 |
| IE42-2 | 29 | MBM-W | 13 | PBX 42-D | 10 | RE24-1/4-3 | 37 |
| IE42-2-3 | 29 | MCD18-1 | 16, 17 | PBX 48-B | 11 | RE24-3/4 | 37 |
| IE42-3-3 | 29 | MCD18-1/3 | 16, 17 | PB 48-B-3 | 11 | RE24-3/4-3 | 37 |
| IE42-3/4 | 29 | MCD18-1/4 | 16, 17 | PB 48-B-HL | 11 | RE30-1 | 37 |
| IE42-3/4-3 | 29 | MCD24-1 | 16, 17 | PB 48-D-OP | 10 | RE30-1 1/2 | 37 |
| IE48-1 | 29 | MCD24-1 1/2 | 16, 17 | PBSX 30-D | 10 | RE30-1 1/2-3 | 37 |
| IE48-1 1/2 | 29 | MCD24-1/2 | 16, 17 | PBSX 36-B | 11 | RE30-1-3 | 37 |
| IE48-1 1/2-3 | 29 | MCD24-1/3 | 16, 17 | PBS 36-B-3 | 11 | RE30-1/2 | 37 |
| IE48-1-3 | 29 | MCD24-1/4 | 16, 17 | PBS 36-B-HL | 11 | RE30-1/2-3 | 37 |
| IE48-2 | 29 | MCD24-3 | 16, 17 | PBSX 36-D | 10 | RE30-1/3 | 37 |
| IE48-2-3 | 29 | MCD24-3/4 | 16, 17 | PBSX 42-B | 11 | RE30-1/3-3 | 37 |
| IE48-3-3 | 29 | MCD30-1 | 16, 17 | PBS 42-B-3 | 11 | RE30-3/4 | 37 |
| IE48-3/4 | 29 | MCD30-1 1/2 | 16, 17 | PBS 42-B-HL | 11 | RE30-3/4-3 | 37 |
| IE48-3/4-3 | 29 | MCD30-1/2 | 16, 17 | PBSX 42-D | 10 | RE36-1 | 37 |
| IE48-5-3 | 29 | MCD30-1/3 | 16, 17 | PBSX 48-B | 11 | RE36-1 1/2 | 37 |
| IE60-2 | 29 | MCD30-2 | 16, 17 | PBS 48-B-3 | 11 | RE36-1 1/2-3 | 37 |
| IE60-2-3 | 29 | MCD30-3 | 16, 17 | PBS 48-B-HL | 11 | RE36-1-3 | 37 |
| IE60-3-3 | 29 | MCD30-3/4 | 16, 17 | PBS 48-D-OP | 10 | RE36-1/2 | 37 |
| IE60-5-3 | 29 | MCD36-1 | 16, 17 | PCBT 36-B | 13 | RE36-1/2-3 | 37 |
| IED12-1/4 | 28 | MCD36-1 1/2 | 16, 17 | PCBT 42-B | 13 | RE36-1/3 | 37 |
| IED12-1/4-3 | 28 | MCD36-2 | 16, 17 | PCBT 48-B | 13 | RE36-1/3-3 | 37 |
| IED16-1/3 | 28 | MCD36-3 | 16, 17 | PDV-305-1MB-BLK-G | 42 | RE36-2 | 37 |

| MODEL | PAGE | MODEL | PAGE | MODEL | PAGE | MODEL | PAGE |
|--------------|------|-------------|------|---------------|------|---------------|------|
| RE36-2-3 | 37 | SBX 42-D | 12 | TXB15-3/4 | 41 | TXB42-2 | 41 |
| RE36-3/4 | 37 | SBX 48-B | 12 | TXB15-3/4-3 | 41 | TXB42-2-3 | 41 |
| RE36-3/4-3 | 37 | SB 48-B-3 | 12 | TXB18-1 | 41 | TXB42-3-3 | 41 |
| RE42-1 | 37 | SB 48-B-HL | 12 | TXB18-1 1/2 | 41 | TXB42-5-3 | 41 |
| RE42-1 1/2 | 37 | SF-12 | 34 | TXB18-1 1/2-3 | 41 | TXB48-5-3 | 41 |
| RE42-1 1/2-3 | 37 | SF-16 | 34 | TXB18-1-3 | 41 | TXB48-7 1/2-3 | 41 |
| RE42-1-3 | 37 | SF-18 | 34 | TXB18-1/2 | 41 | TXD12-1/2 | 39 |
| RE42-1/2 | 37 | SF-20 | 34 | TXB18-1/2-3 | 41 | TXD12-1/2-3 | 39 |
| RE42-1/2-3 | 37 | SF-24 | 34 | TXB18-1/3 | 41 | TXD12-1/4 | 39 |
| RE42-2 | 37 | SLS-18 | 36 | TXB18-1/3-3 | 41 | TXD12-1/4-3 | 39 |
| RE42-2-3 | 37 | SLS-24 | 36 | TXB18-1/4 | 41 | TXD12-3/4 | 39 |
| RE42-3-3 | 37 | SLS-30 | 36 | TXB18-1/4-3 | 41 | TXD12-3/4-3 | 39 |
| RE42-3/4 | 37 | SLS-36 | 36 | TXB24-1 | 41 | TXD18-1 | 39 |
| RE42-3/4-3 | 37 | SLS-42 | 36 | TXB24-1 1/2 | 41 | TXD18-1-3 | 39 |
| RE48-1 | 37 | SLS-48 | 36 | TXB24-1 1/2-3 | 41 | TXD18-1/2 | 39 |
| RE48-1 1/2 | 37 | SLS-54 | 36 | TXB24-1-3 | 41 | TXD18-1/2-3 | 39 |
| RE48-1 1/2-3 | 37 | SLS-60 | 36 | TXB24-1/2 | 41 | TXD18-1/3 | 39 |
| RE48-1-3 | 37 | SR-12 | 34 | TXB24-1/2-3 | 41 | TXD18-1/3-3 | 39 |
| RE48-2 | 37 | SR-16 | 34 | TXB24-2 | 41 | TXD18-1/4 | 39 |
| RE48-2-3 | 37 | SR-18 | 34 | TXB24-2-3 | 41 | TXD18-1/4-3 | 39 |
| RE48-3-3 | 37 | SR-20 | 34 | TXB24-3-3 | 41 | TXD24-1 | 39 |
| RE48-3/4 | 37 | SR-24 | 34 | TXB24-3/4 | 41 | TXD24-1-3 | 39 |
| RE48-3/4-3 | 37 | SW-1 | 16 | TXB24-3/4-3 | 41 | TXD24-1/2 | 39 |
| RE48-5-3 | 37 | SW-1 1/2 | 16 | TXB27-1 | 41 | TXD24-1/2-3 | 39 |
| RE54-1 | 37 | SW-1 1/2-3 | 16 | TXB27-1 1/2 | 41 | TXD24-1/3 | 39 |
| RE54-1 1/2 | 37 | SW-1-3 | 16 | TXB27-1 1/2-3 | 41 | TXD24-1/3-3 | 39 |
| RE54-1 1/2-3 | 37 | SW-1/2 | 16 | TXB27-1-3 | 41 | TXD24-1/4 | 39 |
| RE54-1-3 | 37 | SW-1/2-3 | 16 | TXB27-2 | 41 | TXD24-1/4-3 | 39 |
| RE54-2 | 37 | SW-1/4 | 16 | TXB27-2-3 | 41 | TXD24-2 | 39 |
| RE54-2-3 | 37 | SW-1/4-3 | 16 | TXB27-3/4 | 41 | TXD24-2-3 | 39 |
| RE54-3-3 | 37 | SW-2-3 | 16 | TXB27-3/4-3 | 41 | TXD24-3-3 | 39 |
| RE54-5-3 | 37 | SW-3-3 | 16 | TXB30-1 | 41 | TXD24-3/4 | 39 |
| RE60-1 | 37 | SW-5-3 | 16 | TXB30-1 1/2 | 41 | TXD24-3/4-3 | 39 |
| RE60-1 1/2 | 37 | SW-7 1/2-3 | 16 | TXB30-1 1/2-3 | 41 | TXD27-1 | 39 |
| RE60-1 1/2-3 | 37 | TL-RB-18 | 45 | TXB30-1-3 | 41 | TXD27-1-3 | 39 |
| RE60-1-3 | 37 | TXB12-1/2 | 41 | TXB30-1/2 | 41 | TXD27-1/2 | 39 |
| RE60-2 | 37 | TXB12-1/2-3 | 41 | TXB30-1/2-3 | 41 | TXD27-1/2-3 | 39 |
| RE60-2-3 | 37 | TXB12-1/3 | 41 | TXB30-2 | 41 | TXD27-2 | 39 |
| RE60-3-3 | 37 | TXB12-1/3-3 | 41 | TXB30-2-3 | 41 | TXD27-2-3 | 39 |
| RE60-5-3 | 37 | TXB12-1/4 | 41 | TXB30-3-3 | 41 | TXD30-1/2 | 39 |
| RE60-7 1/2-3 | 37 | TXB12-1/4-3 | 41 | TXB30-5-3 | 41 | TXD30-1/2-3 | 39 |
| SBX 30-D | 12 | TXB12-3/4 | 41 | TXB34-1 1/2 | 41 | TXD30-2 | 39 |
| SBX 36-B | 12 | TXB12-3/4-3 | 41 | TXB34-1 1/2-3 | 41 | TXD30-2-3 | 39 |
| SB 36-B-3 | 12 | TXB15-1/2 | 41 | TXB34-2 | 41 | TXD30-3-3 | 39 |
| SB 36-B-HL | 12 | TXB15-1/2-3 | 41 | TXB34-2-3 | 41 | TXD30-3/4 | 39 |
| SBX 36-D | 12 | TXB15-1/3 | 41 | TXB34-3-3 | 41 | TXD30-3/4-3 | 39 |
| SBX 42-B | 12 | TXB15-1/3-3 | 41 | TXB34-5-3 | 41 | TXD34-1 1/2 | 39 |
| SB 42-B-3 | 12 | TXB15-1/4 | 41 | TXB42-1 1/2 | 41 | TXD34-1 1/2-3 | 39 |
| SB 42-B-HL | 12 | TXB15-1/4-3 | 41 | TXB42-1 1/2-3 | 41 | TXD34-2 | 39 |

Product Index Listing

| MODEL | PAGE | MODEL | PAGE | MODEL | PAGE | MODEL | PAGE |
|---------------|------|---------------|------|---------------|------|-------|------|
| TXD34-2-3 | 39 | UEB36-3/4 | 38 | UED30-1 1/2 | 37 | | |
| TXD34-3-3 | 39 | UEB36-3/4-3 | 38 | UED30-1 1/2-3 | 37 | | |
| TXD34-5-3 | 39 | UEB42-1 | 38 | UED30-1-3 | 37 | | |
| TXD36-2 | 39 | UEB42-1 1/2 | 38 | UED30-2 | 37 | | |
| TXD36-2-3 | 39 | UEB42-1 1/2-3 | 38 | UED30-2-3 | 37 | | |
| TXD36-3-3 | 39 | UEB42-1-3 | 38 | UED30-3-3 | 37 | | |
| TXD42-1-3 | 39 | UEB42-2 | 38 | UED30-3/4 | 37 | | |
| TXD42-2 | 39 | UEB42-2-3 | 38 | UED30-3/4-3 | 37 | | |
| TXD42-2-3 | 39 | UEB42-3-3 | 38 | UED36-2 | 37 | | |
| TXD42-3-3 | 39 | UEB42-3/4 | 38 | UED36-2-3 | 37 | | |
| TXD42-5-3 | 39 | UEB42-3/4-3 | 38 | UED36-3-3 | 37 | | |
| TXD48-3-3 | 39 | UEB48-1 | 38 | UED36-5-3 | 37 | | |
| TXD48-5-3 | 39 | UEB48-1 1/2 | 38 | UED42-2 | 37 | | |
| TXG-12 | 39 | UEB48-1 1/2-3 | 38 | UED42-2-3 | 37 | | |
| TXG-15 | 39 | UEB48-1-3 | 38 | UED42-5-3 | 37 | | |
| TXG-18 | 39 | UEB48-2 | 38 | UED48-10-3 | 37 | | |
| TXG-24 | 39 | UEB48-2-3 | 38 | UED48-3-3 | 37 | | |
| TXG-27 | 39 | UEB48-3-3 | 38 | UED48-5-3 | 37 | | |
| TXG-30 | 39 | UEB48-3/4 | 38 | UED48-7 1/2-3 | 37 | | |
| TXG-34 | 39 | UEB48-3/4-3 | 38 | UED60-5-3 | 37 | | |
| TXG-36 | 39 | UEB54-1 | 38 | UED60-7 1/2-3 | 37 | | |
| TXG-42 | 39 | UEB54-1 1/2 | 38 | UHP 24-P | 4 | | |
| TXG-48 | 39 | UEB54-1 1/2-3 | 38 | UHP 24-PJR | 4 | | |
| U-12-TE | 19 | UEB54-1-3 | 38 | UHP 24-W | 4 | | |
| U-18-CR | 18 | UEB54-2 | 38 | UHP 24-WJR | 4 | | |
| U-18-TE | 19 | UEB54-2-3 | 38 | UHP 30-IJR | 4 | | |
| U-18-TE-HD | 19 | UEB54-3-3 | 38 | UHP 30-P | 4 | | |
| U-24-CR | 18 | UEB54-5-3 | 38 | UHP 30-PJR | 4 | | |
| U-24-TE | 19 | UEB60-1 1/2 | 38 | UHP 30-W | 4 | | |
| U-24-TE-HD | 19 | UEB60-1 1/2-3 | 38 | UHP 30-WJR | 4 | | |
| U-24-TE-HV | 19 | UEB60-2 | 38 | WACM-P | 6 | | |
| UEB24-1/2 | 38 | UEB60-2-3 | 38 | WACM-W | 6 | | |
| UEB24-1/2-3 | 38 | UEB60-3-3 | 38 | WH-12 | 35 | | |
| UEB24-1/3 | 38 | UEB60-5-3 | 38 | WH-16 | 35 | | |
| UEB24-1/3-3 | 38 | UED18-1 | 37 | WH-18 | 35 | | |
| UEB24-3/4 | 38 | UED18-1-3 | 37 | WH-20 | 35 | | |
| UEB24-3/4-3 | 38 | UED18-1/2 | 37 | WH-24 | 35 | | |
| UEB30-1 | 38 | UED18-1/2-3 | 37 | WH-30 | 35 | | |
| UEB30-1-3 | 38 | UED18-1/3 | 37 | WH-36 | 35 | | |
| UEB30-1/2 | 38 | UED18-1/3-3 | 37 | WH-42 | 35 | | |
| UEB30-1/2-3 | 38 | UED18-1/4 | 37 | WH-48 | 35 | | |
| UEB30-3/4 | 38 | UED18-1/4-3 | 37 | WH-60 | 35 | | |
| UEB30-3/4-3 | 38 | UED24-1 | 37 | | | | |
| UEB36-1 | 38 | UED24-1-3 | 37 | | | | |
| UEB36-1 1/2 | 38 | UED24-1/4 | 37 | | | | |
| UEB36-1 1/2-3 | 38 | UED24-1/4-3 | 37 | | | | |
| UEB36-1-3 | 38 | UED24-3-3 | 37 | | | | |
| UEB36-1/2 | 38 | UED24-3/4 | 37 | | | | |
| UEB36-1/2-3 | 38 | UED24-3/4-3 | 37 | | | | |